

# Design, Installation, User & Servicing Instructions

**An unvented hot water storage appliance complying with the requirements of Building Regulations Approved Document G3 and manufactured in accordance with BS EN 12897, the specification for unvented water storage vessels.**

**In the interest of continuously improving the Duplex Unvented Cylinder range, Solfex Limited reserve the right to modify the product without notice, and in these circumstances this booklet, which is accurate at the time of printing, should be disregarded.**



These instructions should be read in conjunction with the installation/servicing instructions issued by the manufacturer of the heat source being used.

Any installation must be in accordance with the relevant requirements of the Gas Safety Regulations, Building Regulations, I.E.E. Wiring Regulations and the Water Fitting Regulations (England and Wales) or Water Byelaws (Scotland). It should be read in accordance with the relevant recommendations of the following:

BS 6798; BS 5549; BS 5546;  
BS 5440:1; BS 5440:2; CP 331:3  
BS 6700; BS 5258 and BS 7593: 1992

Solfex Unvented Cylinder is covered by Section G3 of the Building Regulations (England and Wales) Technical Standard P3 (Scotland) and Building Regulation P5 (Northern Ireland). Compliance can be achieved via a Competent Person Self Certification Scheme or notification of installation to the Local Authority Building Control Department.

It must be installed by a competent person as defined by the relevant regulations. Manufacturers notes must NOT be taken as over-riding statutory obligations.

This appliance is not intended for use by persons (including children) with reduced physical, sensory or mental capabilities, or lack of experience and knowledge unless they have been given supervision or instruction concerning use of the appliance by a person responsible for their safety. Children should be supervised at all times to ensure they do not play with the appliance.

This information is provided to assist generally in the selection of equipment. Responsibility for selection and specification of our equipment must however remain that of our customer and any experts or consultants concerned with the installation(s).

**Please note:** that we do not therefore accept any responsibility for matters of design selection or specification, for the effectiveness of an installation or system containing one of our products unless specifically requested to do so in writing.

All goods are sold subject to our conditions of sale which are set out at the rear of this specification. In the interest of continuously improving the Solfex Unvented Cylinder range, Solfex limited reserve the right to modify the product without notice, and in these circumstances this booklet, which is accurate at the time of printing, should be disregarded. An updated set of instructions will be produced and supplied with new appliances and will be made available for other appliances on request.

**A KIWA product approved to comply with all relevant parts of the Building Regulations and Water Supply (Water Fittings) Regulations. Visit [www.kiwa.co.uk](http://www.kiwa.co.uk) for more information.**

**Solfex Unvented Cylinder is produced under an ISO 9001:2008 Quality Management System approved by BSI.**



Benchmark places responsibilities on both manufacturers and installers. The purpose is to ensure that customers are provided with the correct equipment for their needs, that it is installed, commissioned and serviced in accordance with the manufacturers instructions by competent persons and that it meets the requirements of the appropriate Building Regulations. The Benchmark Checklist can be used to demonstrate compliance with Building Regulations and should be provided to the customer for future reference.

Installers are required to carry out installation, commissioning and servicing work in accordance with the Benchmark Code of Practice which is available from the Heating and Hot Water Industry Council who manage and promote the Scheme. Visit [www.centralheating.co.uk](http://www.centralheating.co.uk) for more information.

## ISSUE 15: JAN 2012

Section	Page
<b>DESIGN</b>	
Description	3
Technical Information	6
System Design	10
<b>INSTALLATION</b>	
Installation	12
Commissioning	22
<b>USER INSTRUCTIONS</b>	23
<b>SERVICING AND MAINTENANCE</b>	
Servicing and Maintenance	24
Fault Finding	25
Short Parts List	28
<b>APPENDIX</b>	
Appendix A	29
Appendix B	30
Notes	31
<b>BENCHMARK</b>	
Commissioning Checklist	32
Service Record	33

## Supplied By: Solfex Limited

Maximum inlet pressure to Pressure reducing valve	12 bar
Operating pressure (PRV setting)	3 bar
Expansion vessel charge pressure	3 bar
Expansion relief valve setting	4.75 bar
Opening pressure of P & T Relief Valve	6 bar
Opening temperature of P & T Relief Valve	95°C
Energy cut-out thermostat setting	80°C
Max. working pressure - Primary heat exchanger (Indirect models)	6 bar
Max. working pressure - Solar heat exchanger (Solar models)	10 bar
Immersion heater rating	3kW, 240V AC

All cylinders are manufactured in accordance with the requirements of EN12897. The tundish must be positioned so that it is visible to the occupant and is away from electrical devices.

Components supplied with Stainless Lite:

- Cold water inlet PRV combination valve/expansion relief
- Pressure and temperature relief valve
- Control thermostat
- Energy cut-out thermostat
- Energy cut-out motorised valve (indirects only)
- Tundish
- 3kW Immersion heater
- Expansion vessel/mounting bracket/flexible hose
- Technical/user product literature

(**Note:** Please refer to tables 1 and 2 on pages 6-9 to confirm the quantity of immersion heaters supplied with the unit)

**In any situation where the volume of heated pipework (eg. secondary circulation pipes or manifold pipework for multiple units) exceeds 10 litres, then an additional expansion vessel must be fitted to accommodate the extra expansion volume.**

## Handling Before Installation

Solfex Unvented Cylinder must be handled with care and stored the correct way up in a dry place. Any manual handling/lifting operations will need to comply with the requirements of the Manual Handling Operations Regulations issued by the H.S.E. The appliance can be moved using a sack truck on the rear face although care should be taken and the route should be even. In apartment buildings containing a number of storeys we would recommend that the appliances are moved vertically in a mechanical lift. If it is proposed to use a crane, expert advice should be obtained regarding the need for slings, lifting beams etc.

A specific manual handling assessment is shown in Appendix B at the rear of this manual.

## Maintenance

Modifications should not be made to this product. Replacement parts, including immersion heaters, should be purchased from Solfex Limited, or agents approved by them. Unvented hot water storage vessels need regular routine checks, and these are detailed below. It is for this reason that this manual must always be left with the Solfex Unvented Cylinder.

It is essential that these checks be carried out at the time of boiler maintenance by a qualified installer:

1. Manually open the relief valves in turn, and check that water is discharged from the valves and runs freely through the tundish and out at the discharge point. Ensure that the valves re-seat satisfactorily. (Note - the water may be very hot).
2. It is important to check that the discharge pipework is carrying the water away adequately. Check for blockages etc. if it is not.
3. Turn the mains water off and remove and clean the strainer element in the Pressure Reducing Valve.
4. Check the charge pressure in the expansion vessel and repressurise if required
5. Re-fill the system and ensure that all relief valves have re-seated.
6. The Benchmark Service Record should be updated at each service.
7. Check the water pressure downstream of the combination valve is 3 bar in static condition.
8. Check and if necessary, descale the heat exchanger in hard water areas ie. above 200ppm (mg/l).

### Note:

The cylinder is factory fitted with a temperature & pressure relief valve that must not be used for any other purpose or removed.

The cylinder is factory fitted with immersion heaters with thermal cut outs. Immersions without thermal cut outs must not be fitted.

Figure 1

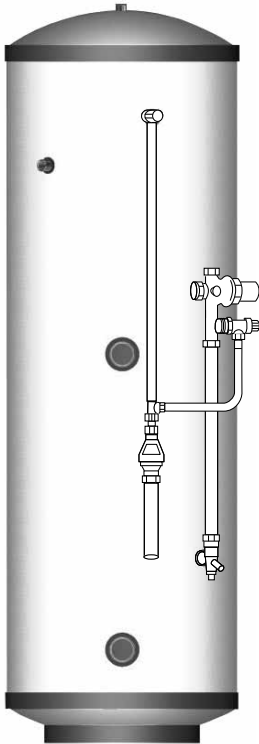

**Solfex Unvented Cylinder  
DIRECT**

Figure 2

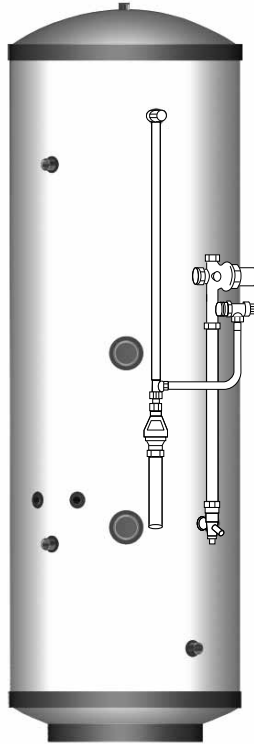

**Solfex Unvented Cylinder  
INDIRECT**

Pipework is not supplied by manufacturer,  
but to be supplied and fitted by installer.

Solfex Unvented Cylinder is a range of unvented hot water storage cylinders, manufactured in the latest high quality duplex stainless steel. They are designed to provide mains pressure hot water and are supplied as a package which complies with Section G3 of the Building Regulations. The appliance is extremely well insulated using high density HCFC free foam insulation with an ozone depleting potential (ODP) of zero and a global warming potential (GWP) of 1. It is fitted with all necessary safety devices and supplied with all the necessary control devices to make installation on site as easy as possible.

**Solfex Unvented Cylinder is available in four basic variants:**

1. **Solfex Unvented Cylinder Direct** - For providing hot water heated by electricity (Figure 1).
2. **Solfex Unvented Cylinder Indirect** - For use with gas or oil boilers (Figure 2). Unvented cylinders must not be used with solid fuel boilers or steam as the energy source.
3. **Solfex Unvented Cylinder Direct Solar** - For providing hot water by solar gains and electricity. (Figure 3).
4. **Solfex Unvented Cylinder Indirect Solar** - For providing hot water by solar gains and gas or oil boilers (Figure 4). Unvented cylinders must not be used with solid fuel boilers or steam as the energy source.

#### **Solfex Unvented Cylinder DIRECT**

Solfex Unvented Cylinder direct is an electrically heated, unvented hot water storage cylinder designed primarily for use with off peak electrical supplies.

It is supplied fitted with two 3kW immersion heaters which are BEAB approved for safety as recommended by the Electricity Council.

Solfex Unvented Cylinder direct models are listed in Table 1 on Page 6 & 7.

#### **Solfex Unvented Cylinder INDIRECT**

Solfex Unvented Cylinder indirect is an unvented hot water storage cylinder and is provided with a high efficiency internal primary coil which is designed for use with a gas or oil boiler and is suitable for both open vented and sealed **pumped** primary systems.

When used with a sealed heating system the boiler must incorporate its own energy cut-out overheat thermostat.

Solfex Unvented Cylinder indirect models are listed in Table 2 on Page 8 & 9.

Figure 3

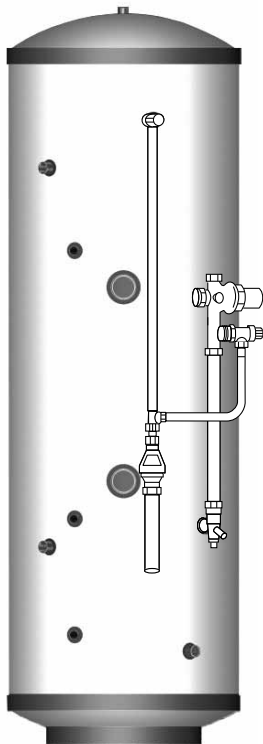

**Solfex Unvented Cylinder  
DIRECT SOLAR**

Figure 4

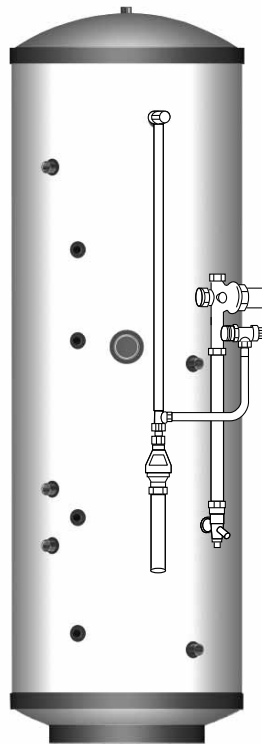

**Solfex Unvented Cylinder  
INDIRECT SOLAR**

Pipework is not supplied by manufacturer,  
but to be supplied and fitted by installer.

### Solfex Unvented Cylinder DIRECT SOLAR

Solfex Unvented Cylinder direct is an electrically heated, unvented hot water storage cylinder designed primarily for use with off peak electrical supplies.

It is supplied fitted with two 3kW immersion heaters which are BEAB approved for safety as recommended by the Electricity Council.

A high efficiency coil is positioned in the lower part of the Solfex Unvented Cylinder vessel to ensure maximum benefit of solar gain energy.

Solfex Unvented Cylinder direct models are listed in Table 1 on Page 6 & 7.

### Solfex Unvented Cylinder INDIRECT SOLAR

Solfex Unvented Cylinder indirect is an unvented hot water storage cylinder and is provided with a high efficiency internal primary coil which is designed for use with a gas or oil boiler and is suitable for both open vented and sealed pumped primary systems.

When used with a sealed heating system the boiler must incorporate its own energy cut-out overheat thermostat.

A high efficiency second solar coil is positioned below the primary coil to ensure maximum benefit of solar gain energy.

Solfex Unvented Cylinder indirect models are listed in Table 2 on Page 8 & 9.

#### Note:

**The cold supply elbow c/w drain tapping must be fitted as shown in figs 1, 2, 3 and 4. A flexible hose can then be connected to the drain tapping and, providing the hose runs below the lowest level of the cylinder, then all the water contents can be drained out by syphonic action. (The cold feed pipe dips internally to the base of the cylinder.)**

# DESIGN

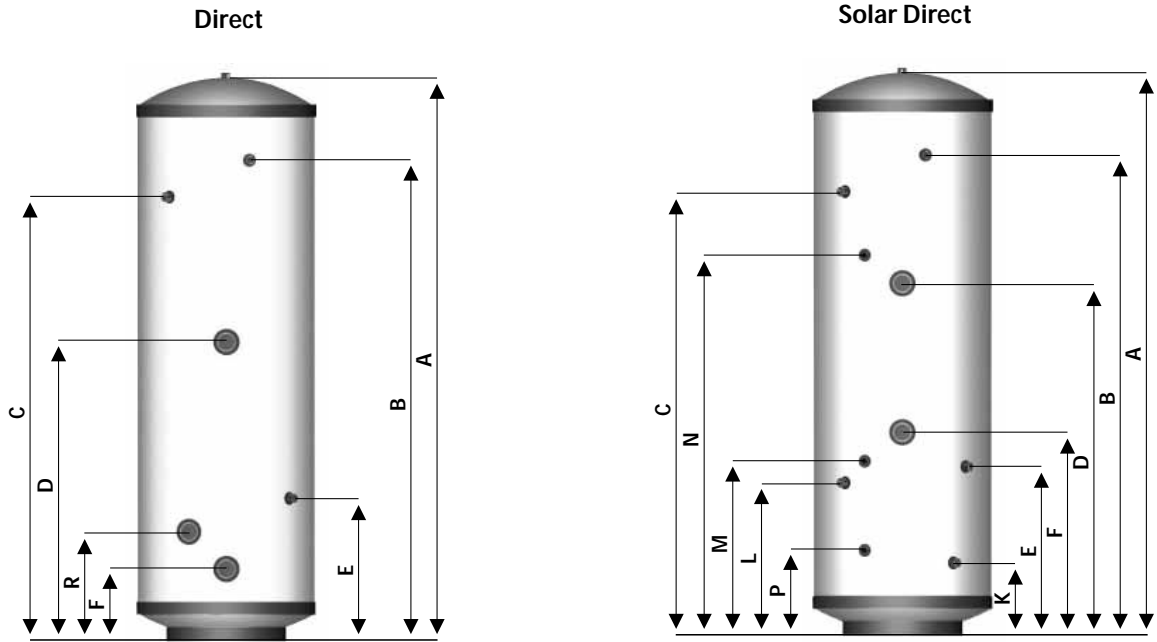

**Table 1**

Model	Weight - Empty	Weight - Full	Capacity (Total Volume)	Pressure Regulator 3 bar inlet group c/w balance cold supply, expansion vessel connection and expansion valve set at 4.75 bar	Expansion Vessel size. Pre-charged to 3 bar	Overall Height	Overall Diameter	Pressure & Temperature Relief Valve 6bar 95°C	22mm Secondary Return Tapping	On Peak Immersion Heater - High Level	Cold Feed 22mm Compression Connection	Off Peak Immersion Heater - Low Level	Volume of On Peak Water Heated	Dual Control & Overheat Stat
	kg	kg	Litres	bar	Litres	A=mm	mm	B=mm	C=mm	D=mm	E=mm	F=mm	Litres	G=mm
<b>Direct</b>														
D90	13	103	90	3	12	732	550	490	n/a	n/a	367	223	n/a	n/a
D120	18	138	120	3	12	920	550	678	n/a	487	367	223	55	n/a
D150	22	172	150	3	18	1107	550	865	n/a	587	442	223	70	n/a
D180	24	204	180	3	18	1295	550	1053	n/a	686	442	223	85	n/a
D210	28	238	210	3	24	1483	550	1241	1127	786	442	223	90	n/a
D250	32	282	250	3	24	1733	550	1491	1377	927	522	223	125	n/a
D300	37	337	300	3	35	2020	550	1777	1577	1077	522	223	155	n/a
D400	48	448	400	3	2 x 24	2040	630	1784	1592	1181	457	238	180	n/a
<b>Direct Slimline</b>														
D60-SL	13	73	60	3	12	704	475	462	n/a	n/a	348	197	n/a	n/a
D90-SL	16	106	90	3	12	976	475	734	n/a	n/a	348	197	n/a	n/a
D120-SL	22	142	120	3	12	1284	475	1006	n/a	650	348	197	55	n/a
D150-SL	30	180	150	3	18	1520	475	1278	n/a	785	423	197	70	n/a
D180-SL	31	211	180	3	18	1790	475	1548	n/a	921	423	197	85	n/a
D210-SL	32	242	210	3	24	2005	475	1763	1580	1147	503	197	90	n/a
<b>Solar Direct</b>														
SOL180d	26	206	180	3	18	1295	550	1053	n/a	746	437	482	75	n/a
SOL210d	30	240	210	3	24	1483	550	1241	1127	908	437	544	80	n/a
SOL250d	34	284	250	3	24	1733	550	1491	1377	1092	522	629	100	n/a
SOL300d	39	339	300	3	35	2020	550	1777	1577	1287	522	724	115	n/a
SOL400d	49	449	400	3	2 x 24	2040	630	1784	1592	1296	557	691	140	n/a
<b>Solar Direct Slimline</b>														
SOL 180d-SL	32	212	180	3	18	1790	475	1548	n/a	1090	423	640	75	n/a
SOL 210d-SL	36	246	210	3	24	2005	475	1763	1589	1190	503	730	80	n/a

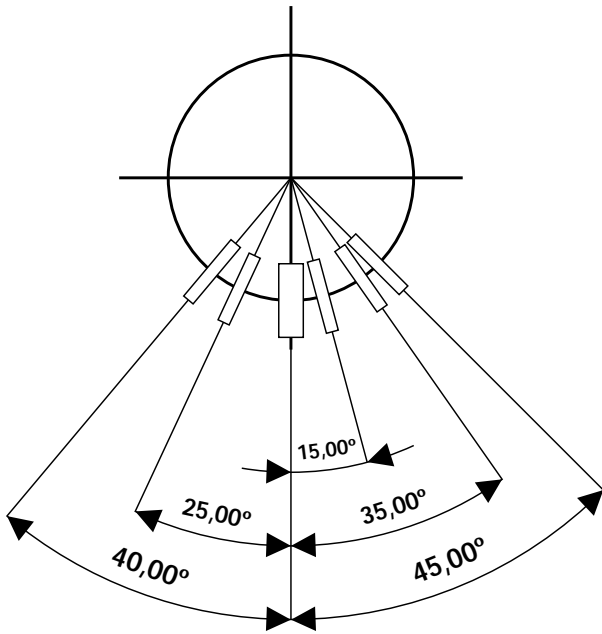

## NOTES

1. Not all models - see table 1.
2. Recovery times based on Primary Coil/I.H.duty (ie. assumes the boiler output is adequate).
3. All connections are supplied with compression fittings for direct connection to copper pipework.
4. The heat up times shown for the D400 model indicate the times when 1 or 2 immersions are connected.
5. The diagrams shown are generic. For exact product specification refer to the table eg. the number of immersion heaters varies depending on model.
6. Heat up and recovery times based on 0.25 l/s primary flow rate and at 82°C flow temperature.

Extra Stat Pocket For Boiler Use If Required	22mm Primary Return Compression Connection (28mm tails for 400 litre model)	22mm Primary Flow Compression Connection (28mm tails for 400 litre model)	22mm Solar Return Compression Connection	22mm Solar Flow Compression Connection	Dual Control & Overheat Stat	Solar Pocket	Solar Pocket	Second Off Peak Immersion Heater - Low Level	kW Rating of Primary Coil	Surface Area of Primary Heater Coil	Pressure Loss Across Primary Heater Coil	Surface Area of Solar Heater Coil	Pressure Loss Across Solar Heater Coil	Heat Up Time from 15°C to 60°C (applies to Primary Heat Source only)	Recovery Time after 70% Draw Off (applies to Primary Heat Source only)	Standing Losses kWh/24hr	Dedicated Solar Volume
H=mm	I=mm	J=mm	K=mm	L=mm	M=mm	N=mm	P=mm	R=mm	kW	m <sup>2</sup>	bar	m <sup>2</sup>	bar	min	min	kWh	Litres
n/a	n/a	n/a	n/a	n/a	n/a	n/a	n/a	n/a	n/a	n/a	n/a	n/a	n/a	90	58	0.80	n/a
n/a	n/a	n/a	n/a	n/a	n/a	n/a	n/a	n/a	n/a	n/a	n/a	n/a	n/a	119	90	1.00	n/a
n/a	n/a	n/a	n/a	n/a	n/a	n/a	n/a	n/a	n/a	n/a	n/a	n/a	n/a	150	121	1.20	n/a
n/a	n/a	n/a	n/a	n/a	n/a	n/a	n/a	n/a	n/a	n/a	n/a	n/a	n/a	179	157	1.40	n/a
n/a	n/a	n/a	n/a	n/a	n/a	n/a	n/a	n/a	n/a	n/a	n/a	n/a	n/a	209	192	1.60	n/a
n/a	n/a	n/a	n/a	n/a	n/a	n/a	n/a	n/a	n/a	n/a	n/a	n/a	n/a	249	224	1.75	n/a
n/a	n/a	n/a	n/a	n/a	n/a	n/a	n/a	n/a	n/a	n/a	n/a	n/a	n/a	299	263	1.93	n/a
n/a	n/a	n/a	n/a	n/a	n/a	n/a	n/a	338	n/a	n/a	n/a	n/a	n/a	398/198	358/179	3.33	n/a
n/a	n/a	n/a	n/a	n/a	n/a	n/a	n/a	n/a	n/a	n/a	n/a	n/a	n/a	60	39	0.95	n/a
n/a	n/a	n/a	n/a	n/a	n/a	n/a	n/a	n/a	n/a	n/a	n/a	n/a	n/a	90	58	1.25	n/a
n/a	n/a	n/a	n/a	n/a	n/a	n/a	n/a	n/a	n/a	n/a	n/a	n/a	n/a	119	90	1.52	n/a
n/a	n/a	n/a	n/a	n/a	n/a	n/a	n/a	n/a	n/a	n/a	n/a	n/a	n/a	150	121	1.77	n/a
n/a	n/a	n/a	n/a	n/a	n/a	n/a	n/a	n/a	n/a	n/a	n/a	n/a	n/a	179	157	2.01	n/a
n/a	n/a	n/a	n/a	n/a	n/a	n/a	n/a	n/a	n/a	n/a	n/a	n/a	n/a	209	192	2.23	n/a
n/a	n/a	n/a	223	352	419	882	203	n/a	n/a	n/a	n/a	0.680	0.191	n/a	90	1.40	60
n/a	n/a	n/a	223	352	419	1000	203	n/a	n/a	n/a	n/a	0.680	0.191	n/a	115	1.60	70
n/a	n/a	n/a	223	472	539	1180	262	n/a	n/a	n/a	n/a	0.970	0.241	n/a	139	1.75	84
n/a	n/a	n/a	223	472	539	1367	262	n/a	n/a	n/a	n/a	0.970	0.241	n/a	187	1.93	100
n/a	n/a	n/a	238	548	651	1383	334	n/a	n/a	n/a	n/a	1.270	0.310	n/a	260	3.33	150
n/a	n/a	n/a	179	329	678	1263	243	n/a	n/a	n/a	n/a	0.680	0.191	n/a	90	2.01	60
n/a	n/a	n/a	179	409	778	1363	273	n/a	n/a	n/a	n/a	0.680	0.191	n/a	115	2.23	70

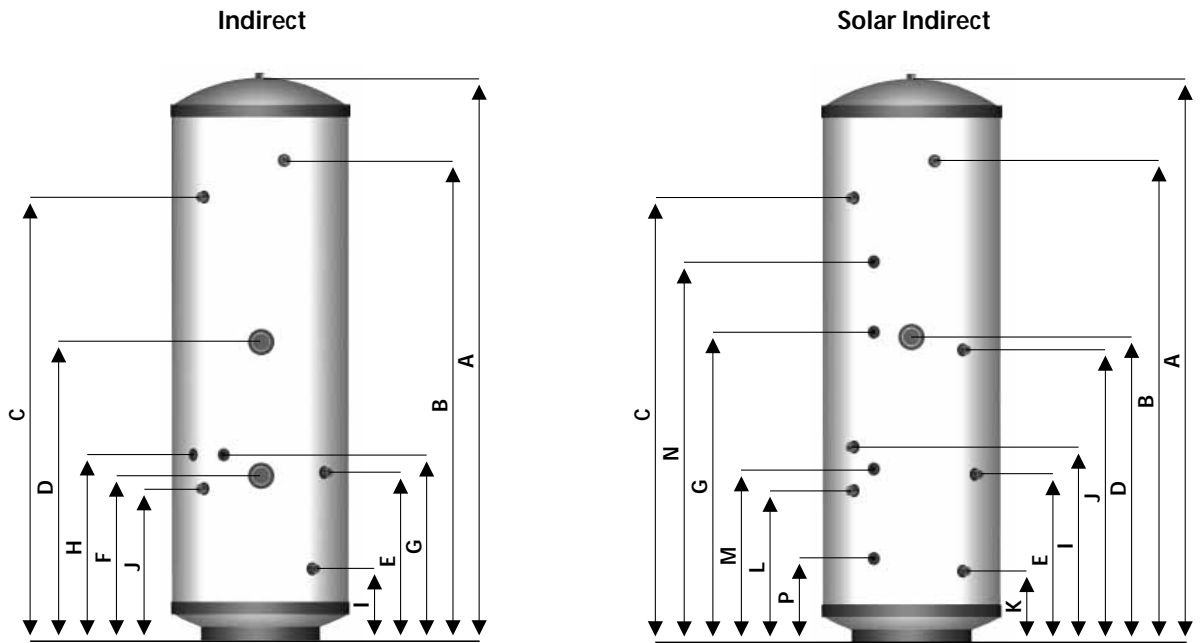

**Table 2**

Model	Weight - Empty	Weight - Full	Capacity (Total Volume)	Pressure Regulator 3 bar inlet group c/w balance cold supply, expansion vessel connection and expansion valve set at 4.75 bar	Expansion Vessel size. Pre-charged to 3 bar	Overall Height	Overall Diameter	Pressure & Temperature Relief Valve 6bar 95°C	22mm Secondary Return Tapping	On Peak Immersion Heater - High Level	Cold Feed 22mm Compression Connection	Off Peak Immersion Heater - Low Level	Volume of On Peak Water Heated	Dual Control & Overheat Stat
	kg	kg	Litres	bar	Litres	A=mm	mm	B=mm	C=mm	D=mm	E=mm	F=mm	Litres	G=mm
Indirect														
IND90	19	109	90	3	12	732	550	490	n/a	352	367	n/a	40	367
IND120	22	142	120	3	12	920	550	678	n/a	352	367	n/a	67	367
IND150	26	176	150	3	18	1107	550	865	n/a	392	442	n/a	92	407
IND180	28	208	180	3	18	1295	550	1053	n/a	432	442	n/a	116	447
IND210	33	243	210	3	24	1483	550	1241	1127	432	442	n/a	145	482
IND250	38	288	250	3	24	1733	550	1491	1377	927	522	512	109	577
IND300	44	344	300	3	35	2020	550	1777	1577	1077	522	512	130	677
IND400	55	455	400	3	2 x 24	2040	630	1777	1577	1151	542	586	180	668
Indirect Slimline														
IND60-SL	14	74	60	3	12	704	475	462	n/a	352	348	n/a	28	242
IND90-SL	19	109	90	3	12	976	475	734	n/a	392	348	n/a	54	359
IND120-SL	23	143	120	3	12	1248	475	1006	n/a	432	348	n/a	75	423
IND150-SL	28	178	150	3	18	1520	475	1278	n/a	462	423	n/a	102	514
IND180-SL	31	211	180	3	18	1790	475	1548	n/a	512	503	n/a	125	604
IND210-SL	34	244	210	3	24	2005	475	1763	1589	512	503	n/a	150	695
Solar Indirect														
SOL180i	30	210	180	3	18	1295	550	1053	n/a	574	437	n/a	80	747
SOL210i	35	245	210	3	24	1483	550	1241	1127	614	437	n/a	95	867
SOL250i	40	290	250	3	24	1733	550	1491	1377	1042	522	n/a	115	994
SOL300i	46	346	300	3	35	2020	550	1777	1577	1155	522	n/a	140	1130
SOL400i	59	459	400	3	2 x 24	2040	630	1792	1592	1129	557	n/a	190	1053
Solar Indirect Slimline														
SOL180i-SL	33	213	180	3	18	1790	475	1548	n/a	1044	423	n/a	75	897
SOL210i-SL	37	247	210	3	24	2005	475	1763	1589	1130	503	n/a	85	1083



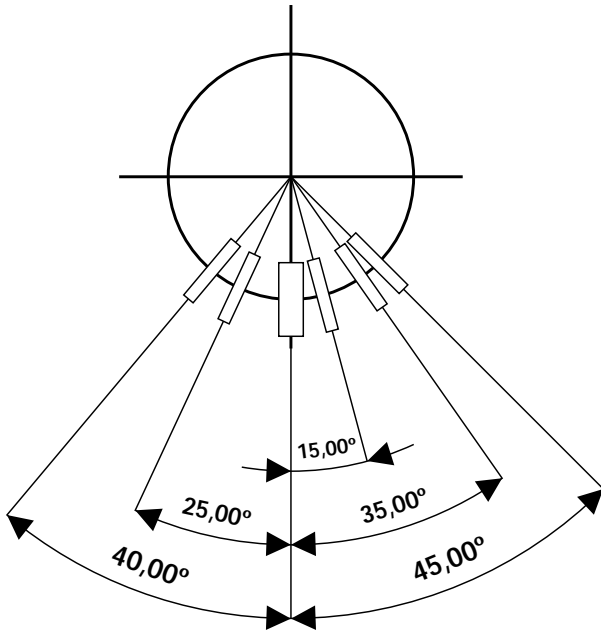

## NOTES

1. Not all models - see table 2.
2. Recovery times based on Primary Coil/I.H. duty (ie. assumes the boiler output is adequate).
3. All connections are supplied with compression fittings for direct connection to copper pipework.
4. The diagrams shown are generic. For exact product specification refer to the table eg. the number of immersion heaters varies depending on model.
5. Heat up and recovery times based on 0.25 l/s primary flow rate and at 82°C flow temperature.

Extra Stat Pocket For Boiler Use If Required	22mm Primary Return Compression Connection (28mm tails for 400 litre model)	22mm Primary Flow Compression Connection (28mm tails for 400 litre model)	22mm Solar Return Compression Connection	22mm Solar Flow Compression Connection	Dual Control & Overheat Stat	Solar Pocket	Solar Pocket	Second Off Peak Immersion Heater - Low Level	kW Rating of Primary Coil	Surface Area of Primary Heater Coil	Pressure Loss Across Primary Heater Coil	Surface Area of Solar Heater Coil	Pressure Loss Across Solar Heater Coil	Heat Up Time from 15°C to 60°C (applies to Primary Heat Source only)	Recovery Time after 70% Draw Off (applies to Primary Heat Source only)	Standing Losses kWh/24hr	Dedicated Solar Volume
H=mm	I=mm	J=mm	K=mm	L=mm	M=mm	N=mm	P=mm	R=mm	kW	m <sup>2</sup>	bar	m <sup>2</sup>	bar	min	min	kWh	Litres
367	223	312	n/a	n/a	n/a	n/a	n/a	n/a	16.5	0.59	0.165	n/a	n/a	21	16	0.80	n/a
367	223	312	n/a	n/a	n/a	n/a	n/a	n/a	18	0.59	0.165	n/a	n/a	27	19	1.00	n/a
407	223	392	n/a	n/a	n/a	n/a	n/a	n/a	18.5	0.68	0.191	n/a	n/a	28	19	1.20	n/a
447	223	392	n/a	n/a	n/a	n/a	n/a	n/a	19	0.78	0.216	n/a	n/a	33	21	1.40	n/a
482	223	392	n/a	n/a	n/a	n/a	n/a	n/a	20.5	0.78	0.216	n/a	n/a	41	26	1.60	n/a
577	223	472	n/a	n/a	n/a	n/a	n/a	n/a	21.5	0.97	0.241	n/a	n/a	44	30	1.75	n/a
677	223	522	n/a	n/a	n/a	n/a	n/a	n/a	25	0.97	0.241	n/a	n/a	48	32	1.93	n/a
668	223	533	n/a	n/a	n/a	n/a	n/a	n/a	30.5	1.27	0.310	n/a	n/a	55	36	3.33	n/a
242	179	329	n/a	n/a	n/a	n/a	n/a	n/a	15	0.59	0.165	n/a	n/a	14	11	0.95	n/a
359	179	329	n/a	n/a	n/a	n/a	n/a	n/a	16.5	0.59	0.165	n/a	n/a	21	16	1.25	n/a
423	179	329	n/a	n/a	n/a	n/a	n/a	n/a	18	0.59	0.165	n/a	n/a	27	19	1.52	n/a
514	179	409	n/a	n/a	n/a	n/a	n/a	n/a	18.5	0.68	0.191	n/a	n/a	28	19	1.77	n/a
604	179	449	n/a	n/a	n/a	n/a	n/a	n/a	19.0	0.78	0.216	n/a	n/a	33	21	2.01	n/a
695	179	449	n/a	n/a	n/a	n/a	n/a	n/a	20.5	0.78	0.216	n/a	n/a	41	26	2.23	n/a
n/a	614	834	223	352	419	882	218	n/a	18	0.59	0.165	0.680	0.191	28	16	1.40	96
n/a	654	914	223	352	419	1000	233	n/a	18.5	0.68	0.191	0.680	0.191	35	16	1.60	101
n/a	702	1002	223	472	539	1180	294	n/a	19	0.78	0.216	0.970	0.241	38	19	1.75	107
n/a	815	1115	223	472	539	1367	300	n/a	20.5	0.78	0.216	0.970	0.241	41	20	1.93	125
1053	766	1026	238	548	651	1383	357	n/a	22	0.97	0.241	1.270	0.310	45	24	3.33	165
n/a	619	1004	179	320	583	1232	243	n/a	18	0.59	0.165	0.680	0.191	28	16	2.01	60
n/a	710	1095	179	409	673	1383	273	n/a	18.5	0.68	0.191	0.680	0.191	35	16	2.23	70

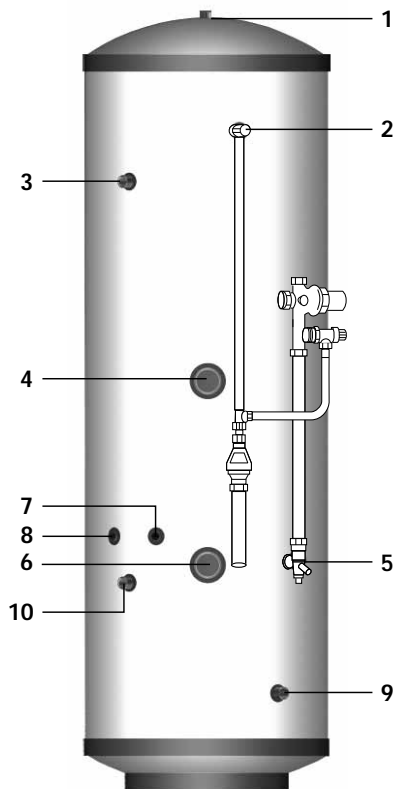
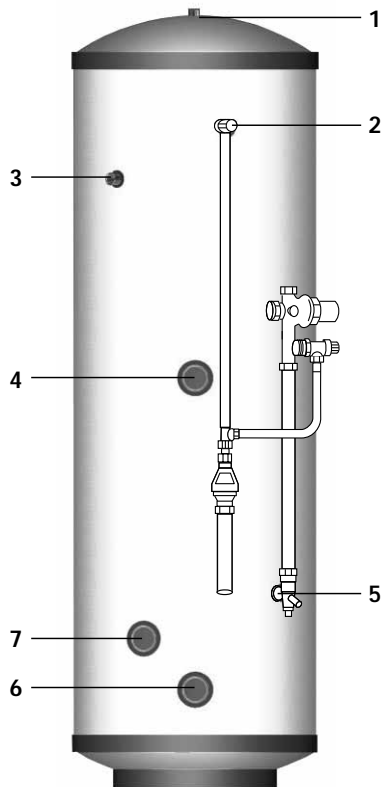

## Solfex Unvented Cylinder Direct

### Basic Appliance

1. Hot water draw off (22mm) compression
2. Temperature & pressure relief valve 95°/6 bar
3. Hot water secondary return 22mm (not fitted to smaller sizes, see table 1)
4. Immersion heater 1¾" BSP 3kW (normally on-peak)
5. 22mm cold supply compression
6. Immersion heater 1¾" BSP 3kW (normally off-peak)
7. Immersion heater 1¾" BSP 3kW (normally off-peak - 400 litre model only)

### Component kit supplied separately

- A. Combination inlet group incorporating pressure reducing valve, strainer, check valve, balance cold take off point, expansion relief valve and expansion vessel connection points.
- B. Portable expansion vessels c/w flexible hose and wall bracket
- C. Tundish

## Solfex Unvented Cylinder Indirect

### Basic Appliance

1. Hot water draw off (22mm) compression
2. Temperature & pressure relief valve 95°/6 bar
3. Hot water secondary return 22mm (not fitted to smaller sizes, see table 2)
4. Immersion heater 1¾" BSP 3kW
5. 22mm cold supply compression
6. Immersion heater 1¾" BSP 3kW
7. Dual control/overheat stat pocket (22mm)
8. Boiler control sensor pocket (spare)
9. Primary return (22mm) - (28mm tails for 400 litre models)
10. Primary flow (22mm) - (28mm tails for 400 litre models)

### Component kit supplied separately

- A. Combination inlet group incorporating pressure reducing valve, strainer, check valve, balance cold take off point, expansion relief valve and expansion vessel connection points.
- B. Potable expansion vessels c/w flexible hose and wall bracket
- C. Tundish
- D. Dual control thermostat and combined overheat thermostat
- E. Two port (22mm) zone valve for primary circuit
- F. Wiring junction box for primary system

Typical arrangement of component kit shown fitted to the appliance for clarity  
**Pipework to be supplied and fitted by installer.**

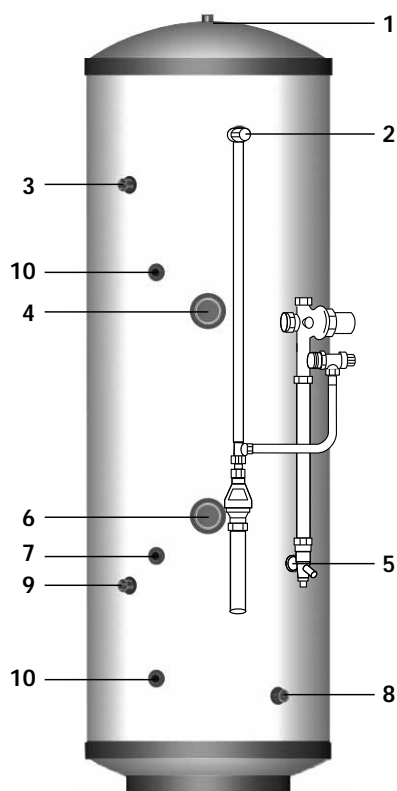

## Solfex Unvented Cylinder Direct Solar

### Basic Appliance

1. Hot water draw off (22mm) compression
2. Temperature & pressure relief valve 95°/6 bar
3. Hot water secondary return 22mm (not fitted to smaller sizes, see table 1)
4. Immersion heater 1¾" BSP 3kW (normally on-peak)
5. 22mm cold supply
6. Immersion heater 1¾" BSP 3kW (normally off-peak)
7. Dual control/Overheat stat pocket
8. Solar coil return to panel collector (22mm) compression
9. Solar coil flow from panel (22mm) compression
10. Solar thermostat pocket

### Component kit supplied separately

- A. Combination inlet group incorporating pressure reducing valve, strainer, check valve, balance cold take off point, expansion relief valve and expansion vessel connection points.
- B. Portable expansion vessels c/w flexible hose and wall bracket
- C. Tundish
- D. Dual control thermostat and combined overheat thermostat

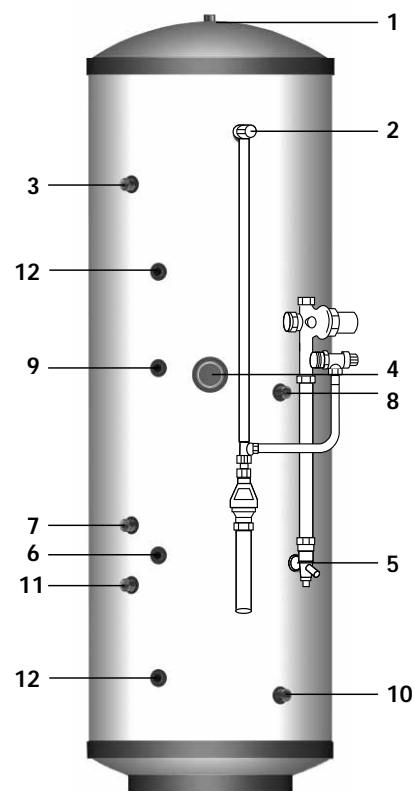

## Solfex Unvented Cylinder Indirect Solar

### Basic Appliance

1. Hot water draw off (22mm) compression
2. Temperature & pressure relief valve 95°/6 bar
3. Hot water secondary return 22mm (not fitted to smaller sizes, see table 2)
4. Immersion heater 1¾" BSP 3kW
5. 22mm cold supply
6. Dual control/Overheat stat pocket
7. Primary return (22mm) - (28mm tails for 400 litre models)
8. Primary flow (22mm) - (28mm tails for 400 litre models)
9. Dual control/Overheat stat pocket
10. Solar coil return to panel collector (22mm) compression
11. Solar coil flow from panel (22mm) compression
12. Solar thermostat pocket

### Component kit supplied separately

- A. Combination inlet group incorporating pressure reducing valve, strainer, check valve, balance cold take off point, expansion relief valve and expansion vessel connection points.
- B. Potable expansion vessels c/w flexible hose and wall bracket
- C. Tundish
- D. Dual control thermostat and combined overheat thermostat (x2)
- E. Two port (22mm) zone valve for primary circuit
- F. Wiring junction box for primary system

Typical arrangement of component kit shown fitted to the appliance for clarity  
**Pipework to be supplied and fitted by installer.**

# INSTALLATION

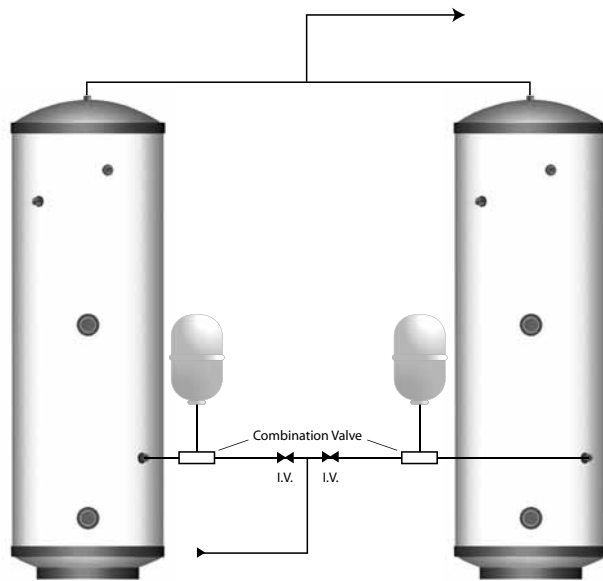

If two Solfex Unvented Cylinders are coupled together the secondary inlet and outlet pipes must be balanced. The units must be fitted on the same level.

**Note: No valves must be fitted between the expansion vessel and the storage cylinder(s).**

Standard and Slimline Model Selection Guide			
Max hot water demand	Max number of bed spaces (Bedrooms)	Indirect litres	Direct litres
1 shower room	Bedsit (0)	90	120
1 bathroom	2 (2)	120	150
1 bathroom	4 (3)	120	180
1 bathroom + separate shower room	6 (4)	150	210
1 bathroom + 2 separate shower rooms or 2 bathrooms	7 (5)	180	210
2 bathrooms + separate shower room	7 (5)	210	250
2 bathrooms + 2 separate shower rooms	7 (5)	250	300
3 bathrooms + 2 separate showers rooms	9 (6)	300	400
3 bathrooms + 3 separate showers rooms	9 (6)	400	-

Solar Model Selection Guide				
Max hot water demand	Max floor area (m <sup>2</sup> )	Bedrooms	Indirect litres	Direct litres
1 shower room	44	Bedsit	-	180
1 bathroom	44	1-3	180	-
1 bathroom	66	1-3	-	210
1 bathroom + 1 shower room	66	1-3	210	-
1 bathroom + 1 shower room	84	1-3	-	250
1 bathroom + 2 shower rooms	84	2-4	250	-
1 bathroom + 2 shower rooms	113	2-4	-	300
2 bathrooms + 1 shower room	113	3-4	300	-
2 bathrooms + 1 shower room	150	4-5	-	400
2 bathrooms + 2 shower rooms	150	4-5	400	-

## General Design Considerations

The cupboard footprint needs to be at least 650mm square for standard units up to 300 litres, 730mm for 400 litre and 575mm for slimline units.

The base chosen for the cylinder should be level and capable of supporting the weight of the unit when full of water as shown in General Data. The discharge pipework for the safety valves must have a minimum fall of 1 : 200 from the unit to a safe discharge point. All exposed pipework should be insulated and the unit should NOT be fixed in a location where the contents could freeze.

**The pipe connecting the boiler flow to the appliance must not be less than 22mm copper or equivalent.**

## Mains Water Supply

Existing properties with a 15mm supply will be satisfactory provided the local mains pressure is good, but should be confined to single bathroom properties. For new properties where simultaneous demand is required to more than one bathroom or a bathroom and one or more en-suites, the communication and service pipe into the dwelling should be a minimum of 22mm (usually in the form of a 25mm MDPE supply). The optimum performance is achieved if the inlet pressure is 3 bar dynamic. However, the Solfex unvented cylinder will function with lower inlet pressures, but this will reduce the performance. There should be a flow of at least 30 litres per minute or above available into the property. Normally Solfex Unvented Cylinder provides well in excess of 40 litres/min in most conditions. Flow rates for ALL mains pressure systems are subject to district pressures and system dynamic loss. Particularly on larger properties with more than one bathroom, the pipe sizes should be calculated in accordance with BS6700.

## Model Selection

The suggested Direct model sizes, shown opposite, are based on a typical days hot water use assuming an Economy 7 tariff is provided. A reduction of one model size can normally be made with an Economy 10 tariff. When using the Direct models for high specification developments an increase of one model size should be considered.

Where selecting a solar model, it is important to check the dedicated solar volume (shown in tables 1 & 2) is suitable for the total floor area of the dwelling to ensure compliance with Building Regulations. The maximum floor area of the dwelling permitted for the models is shown opposite.

The suggested model sizes are based on typical hot water usage. For high specification dwellings an increase of one model size should be considered.

## General Restrictions

- The highest hot or cold water draw off point should not exceed 10 metres above the Pressure Reducing Valve.
- An ascending spray type bidet or any other appliance with a Class 1 back-syphonage risk requiring a type A air gap should not be used.
- Solfex Unvented Cylinder should not be used where steam is the primary heating medium, or in a situation where maintenance is likely to be neglected.
- Unvented cylinders are not suitable for use with solid fuel boilers.
- If the supply to the mixer fittings (other than a dual outlet type) is not taken from the balanced supply the system will become over pressurized and cause the pressure relief valve to discharge. Over time this could also cause the premature failure of the appliance itself which will not be covered by the warranty,**
- In larger properties with a number of bathrooms/en-suites and long pipe runs we would recommend that the balance cold supply is provided with its own pressure reducing valve and is not taken from the balanced cold connection on the combination valve. In this case it will also be necessary to fit a small expansion vessel on the balanced cold water system to accommodate the pressure rise caused by the increase in temperature of the balanced cold water.
- Check the performance requirements of the terminal fittings with regard to flow/pressure are suitable.
- In relation to potable water systems, expansion vessels shall be installed in a vertical orientation and located so that the length of the connecting pipe work is kept to a minimum.

## Shower Fittings

Aerated taps are recommended to prevent splashing. Any type of shower mixing valve can be used as long as both the hot and cold supplies are mains fed. However, all mains pressure systems are subject to dynamic changes particularly when other hot and cold taps/showers are opened and closed, which will cause changes in the water temperature at mixed water outlets such as showers. For this reason and because these are now no more expensive than a manual shower we strongly recommend the use of thermostatic showers with this appliance. These must be used in 3 storey properties where the impact on pressure/temperature of opening another tap in

the system is greater than normal. The shower head provided must also be suitable for mains pressure supplies.

## Pipe Layout

In all mains pressure installations it is important to remember that the incoming cold supply must be shared between all terminal fittings. It is important that a 22mm supply is brought to the appliance and a 22mm take-off is continued at least to the bath. If there are two baths, 28mm pipework should be considered. One metre of smaller diameter pipework, or flow restrictors, should be provided on the final connection to all outlets so as to balance the water available. In any event the distribution pipework should generally be in accordance with EN806:1.

## Plastic Pipework

This appliance is suitable for use with plastic pipework as long as the material is recommended for the purpose by the manufacturer and is installed fully in accordance with their recommendations.

## Secondary Hot Water Circulation

Some models are fitted with a secondary return tapping as standard (see tables 1 & 2 for details). If fitted, an extra expansion vessel may be necessary. A non-return valve MUST be FITTED near the return connection. No valve or terminal fitting should be installed between the non return valve and the cylinder. (See schematic arrangement on page 15.)

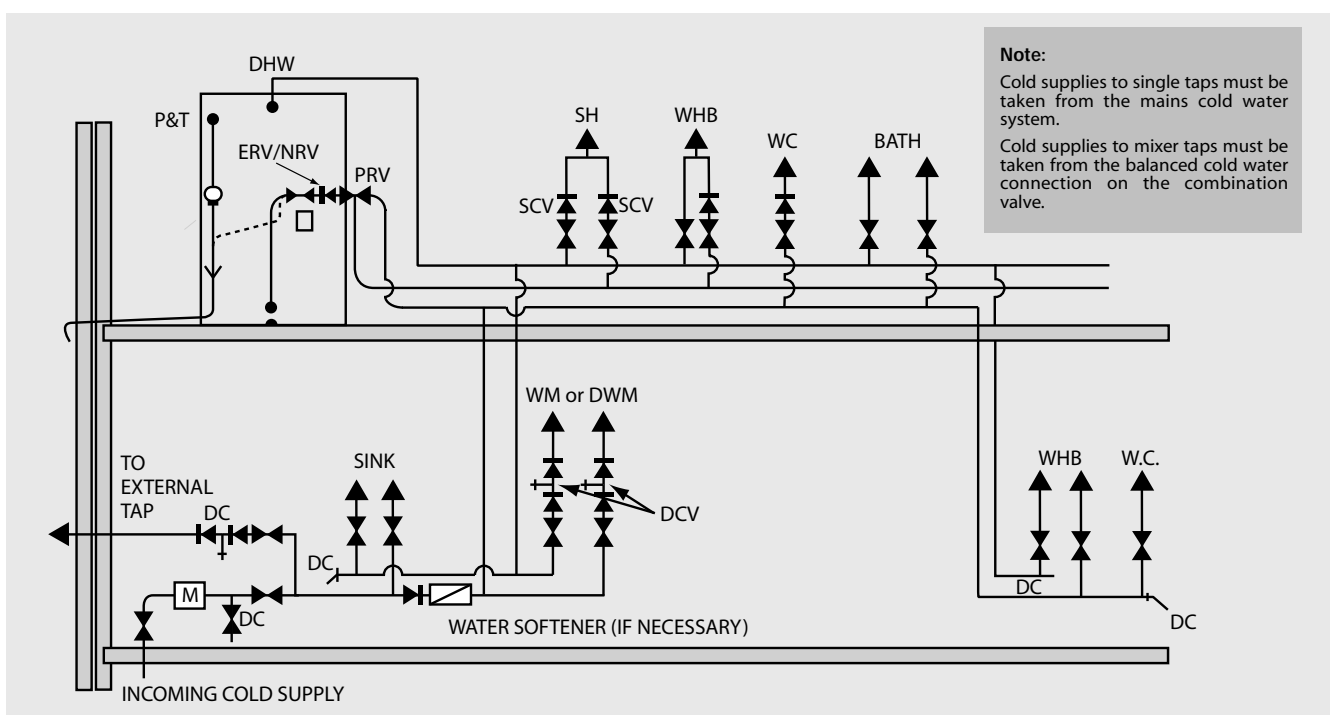

# INSTALLATION

**Typical Discharge Pipe Arrangement**

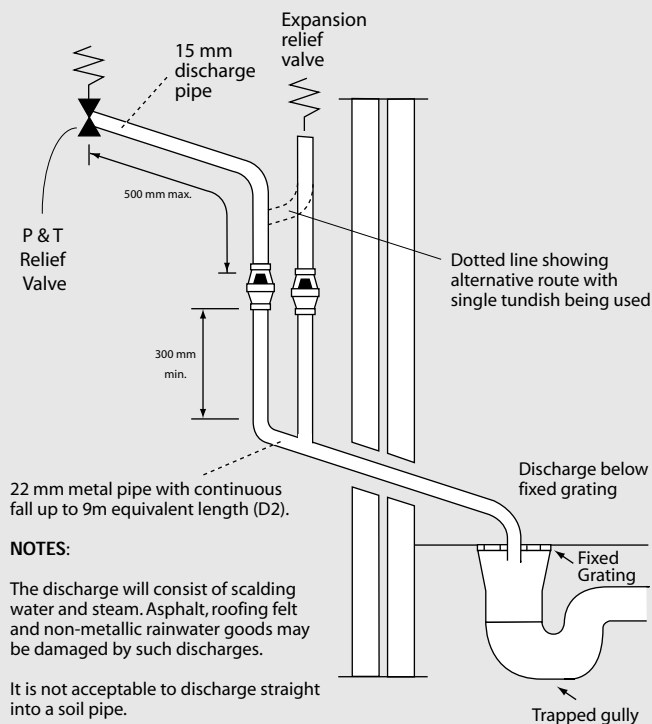

## Pressure & Temperature/expansion Relief Valve Pipework

The relief valve should be installed to discharge in accordance with G3 of the Approved Document of the Building Regulations and should be piped to where it is visible, but will not cause danger to persons or damage to materials.

The following information is taken from Approved Document G3 of the Building Regulations and is provided to assist with the design and installation of the discharge pipework. However, the information is not exhaustive and reference should always be made to Approved Document G3 of the Building Regulations. The final decision regarding any arrangements rests with Building Control and it is recommended that their advice is sought if you have any concerns regarding this aspect of the installation.

The two safety valves will only discharge water under fault conditions. When operating normally water will not be discharged.

The tundish should be vertical, located in the same space as the unvented hot water storage system and be fitted as close as possible and within 500mm of the safety device e.g. the temperature relief valve.

The discharge pipe (D2) from the tundish should terminate in a safe place where there is no risk to persons in the vicinity of the discharge, be of metal and:

- Be at least one pipe size larger than the nominal outlet size of the safety device unless its total equivalent hydraulic resistance exceeds that of a straight pipe 9m long i.e. discharge pipes between 9m and 18m equivalent resistance length should be at least two sizes larger than the nominal outlet size of the safety device, between 18 and 27m at least 3 sizes larger, and so on. Bends must be taken into account in calculating the flow resistance. Refer to the table and the worked example.

An alternative approach for sizing discharge pipes would be to follow BS6700 Specification for design installation, testing and maintenance of services supplying water for domestic use within buildings and their curtilages.

- Have a vertical section of pipe at least 300mm long, below the tundish before any elbows or bends in the pipe work.

- Be installed with a continuous fall.

## WORKED EXAMPLE

The example below is for G1/2 temperature relief valve with a discharge pipe (D2) having 4 elbows and length of 7m from the tundish to the point of discharge.

From the table below:

Maximum resistance allowed for a straight length of 22mm copper discharge pipe (D2) from a G1/2 temperature relief valve is: 9m subtract the resistance for 4 x 22mm elbows at 0.8m each = 3.2m.

Therefore the maximum permitted length equates to: 5.8m.

5.8m is less than the actual length of 7m therefore calculate the next largest size.

Maximum resistance allowed for a straight length of 28mm pipe (D2) from a G1/2 temperature relief valve equates to: 14m.

As the actual length is 7m, a 28mm (D2) copper pipe will be satisfactory.

**Sizing of copper discharge pipe 'D2' for a temperature relief valve with a G1/2 outlet size (as supplied)**

Size of discharge pipework	Maximum length of straight pipe (no bends or elbows)	Deduct the figure below from the maximum length for each bend or elbow in the discharge pipe
22mm	Up to 9m	0.8m
28mm	Up to 18m	1m
35mm	Up to 27m	1.4m

d) It is preferable for the discharge to be visible at both the tundish and the final point of discharge but where this is not possible or practically difficult there should be clear visibility at one or other of these locations. Examples of acceptable discharge arrangements are:

1. Ideally below the fixed grating and above the water seal in a trapped gully.
2. Downward discharges at a low level; i.e. up to 100mm above external surfaces such as car parks, hard standings, grassed areas etc are acceptable providing that where children play or otherwise come into contact with discharges, a wire cage or similar guard is positioned to prevent contact whilst maintaining visibility.
3. Discharges at a high level; e.g. into metal hopper and metal down pipe with the end of the discharge pipe clearly visible (tundish visible or not) or onto a roof capable of withstanding high temperature discharges of water and 3m from any plastic guttering systems that would collect such discharges.
4. Where a single pipe serves a number of discharges, such as in blocks of flats, the number served should be limited to not more than 6 systems so that any installation can be traced reasonably easily. The single common discharge pipe should be at least one pipe size larger than the largest individual discharge pipe to be connected. If unvented hot water storage systems are installed where discharges form safety devices may not be apparent i.e. in dwellings occupied by blind, infirm or disabled people, consideration should be given to the installation of an electronically operated device to warn when discharge takes place.

## Safety

The safety devices supplied or fitted on an Solfex Unvented Cylinder are selected for their suitability for the temperatures and pressures involved. They must not be changed, removed or by-passed and it is essential that only genuine replacement parts supplied or approved by Solfex Limited are used. This includes the immersion heaters, which must incorporate an energy cut-out. All parts are available to approved installers from Solfex Limited.

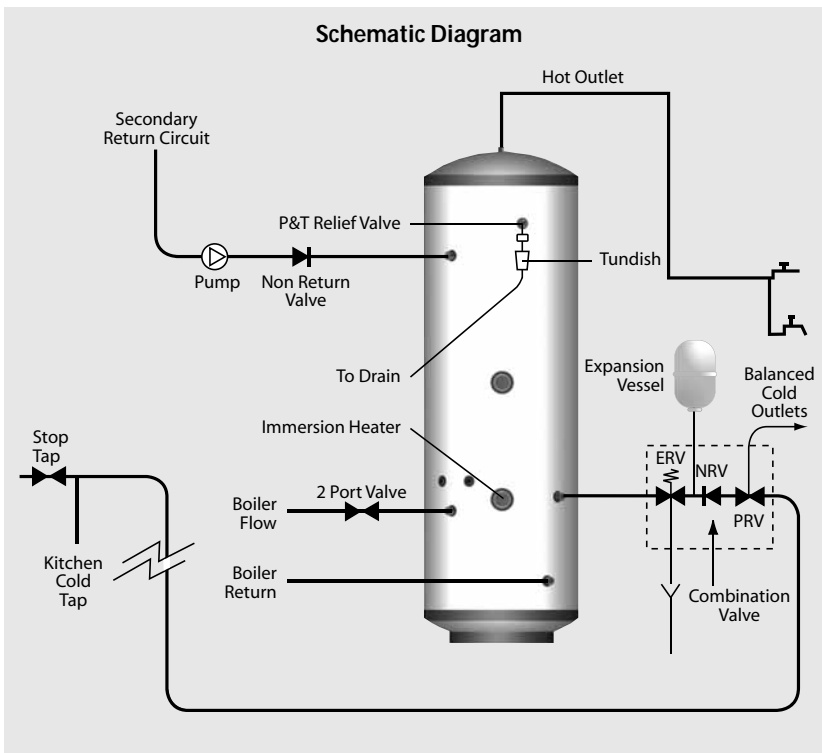

## Combination Inlet Group

Combines elements 1, 2 and 3 below.

1. *Pressure Reducing Valve* - This must be fixed near the cylinder. The cold water supply to any mixer taps/showers must be taken from the cold water supply to this valve to ensure balanced hot and cold pressures. This valve is factory set to ensure the correct operating pressure for the Solfex Unvented Cylinder.
2. *Non Return Valve* - This is integral with the pressure reducing valve to prevent backflow of hot water towards cold water draw off points.
3. *Cold Water Expansion Relief Valve* - This safety device is preset at the factory and will relieve excess cold water pressure resulting from a fault condition.

# INSTALLATION

## Temperature/Pressure Relief Valve

This safety device is also pre-set at the factory and relieves before the temperature reaches 100°C. It is also a Pressure Relief Valve, and is pre-set to 6 bar.

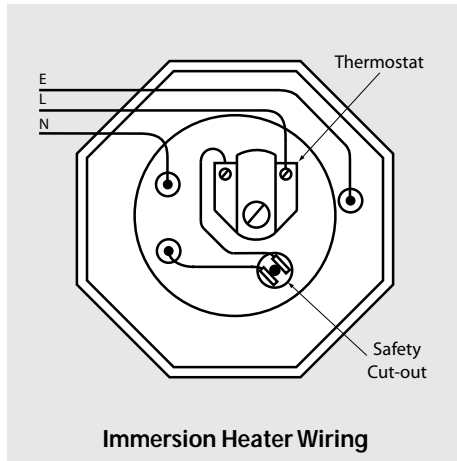

## Immersion Heaters

These are 3kW 240V AC heaters and incorporate a thermostat and a manually reset energy cut-out which operates at 80°C. They have incolloy elements to prolong their life expectancy in aggressive water conditions.

Please refer to tables 1 and 2 to clarify how many off peak and on peak immersions are included with the unit you require.

Where it is intended that units are fitted to offpeak circuits, then suitable controllers such as the Horstmann off peak electric time controller will be required. External wiring to the immersion heaters must be in accordance with the relevant IEE Wiring Regulations and the circuit must be protected by a suitable fuse and a double pole isolating switch.

The correct method of terminating the wiring to the immersion heater is shown above.

Usage of the product in non-domestic commercial applications can be extremely intensive and stressful to various components. We recommend that titanium immersion heaters are fitted in such situations, rather than the incoloy heater supplied as standard. Titanium immersion heaters offer superior strength, weight and a smoother finish which enable them to better withstand the extreme stress and temperature fluctuation often encountered within non-domestic environments and situations where water quality is poor – ensuring improved performance and extended operational life.

## Line Strainer

This is integral within the combination inlet group to reduce the likelihood of contaminants fouling the valve seat. Following installation this line strainer must be cleaned and replaced. This needs to be carried out on a regular basis, as part of the annual maintenance/service check.

## Tundish

This is to allow the discharge from any Relief Valve to be seen. It must be fitted away from any electrical devices. See page 14 for discharge pipework details.

## Safety

The immersion heaters must be earthed and they must be isolated from the mains before the cover is removed on every occasion. Replacement immersion heaters should be obtained from Solfex Limited.

## Control/Overheat Dual Thermostats

Care must be taken to ensure that the solar probes are fully inserted into the pockets provided.

## Anti Vacuum Valve

**Important** - failure to follow the drain down procedure will invalidate the warranty.(see page 22)

**NEVER** drain the cylinder of hot water and then close all cylinder inlets and outlets.

**REASON** as the air remaining in the cylinder cools the pressure inside the cylinder will fall below atmospheric and cause the cylinder to implode.

**NEVER** close the cold main and drain the cylinder via any tap connected to it.

**REASON** as the water drains, the pressure inside the cylinder may decrease below atmospheric and this will cause the cylinder to implode.

To stop the possibility of this occurring by accident an ANTI VACUUM VALVE should be fitted in the hot water take off pipe. This will balance the cylinder's internal and atmospheric pressures and eliminate this risk.

Available from Gledhill part number GT056.



**Schematic Open Vented Primary System**

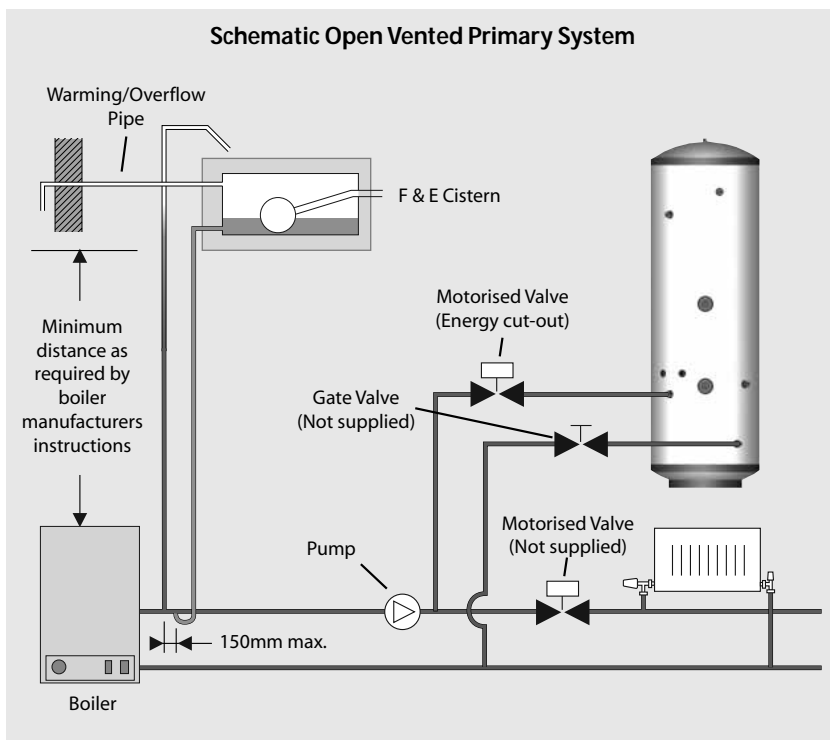

**Schematic Sealed Primary System**

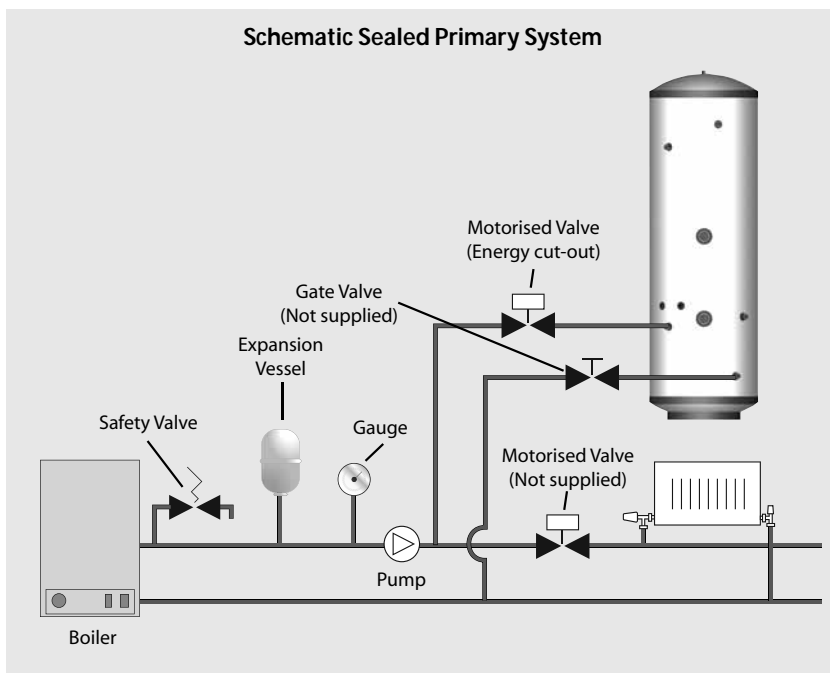

## Heating/primary Systems

The boiler and primary/heating systems should be sized and installed in accordance with BS 5449.

## Safety

Solfex Unvented Cylinder is fitted with a Combined Temperature/Pressure Relief Valve to cope with any increase in system temperature and pressure above the design limitations, when used with boilers up to 45kW output, which is the maximum allowed by section G3 of the Building Regulations. The primary water temperatures should be controlled as outlined below.

## Primary Circuit

It is essential that the circuit between the boiler and the Solfex Unvented Cylinder is pumped. The motorised zone valve supplied should be fitted adjacent to the unit and controlled by the cylinder thermostat supplied. The thermostat and motorised valve must be wired so that they both switch off should an overheat situation develop. It is important to follow the wiring diagram in the Wiring Section of these instructions.

## Sealed Primary Circuit

Any boiler used must be fitted with an over temperature cut-out. Unvented primary circuits may be filled or replenished by means of a temporary connection between the circuit and a supply pipe provided a 'Listed' double check valve or some other no less effective backflow prevention device is permanently connected at the inlet to the circuit and the temporary connection is removed after use.

Alternatively, a CA device can be used, which will allow the system to be permanently connected to the cold mains supply. The primary system can then be topped up, when required, in the same way as an open vented system fitted with an F&E Cistern.

## Gate Valve

All our cylinders are tested to BS EN 12897 at 15 l/mim at which they exceed the minimum requirements for heat up performance and reheat in less time than the maximum reheat times.

In extreme situations where excessive flow rates, above 25 l/min are present, then a gate valve on the return from the cylinder to the boiler, before it joins the central heating return, may be required to reduce excessive flow rates and therefore any potential noise problems.

# INSTALLATION

### Schematic Solar Direct System

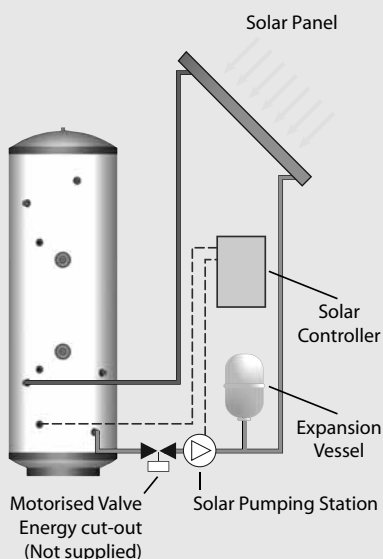

All components in a solar primary system must be marked or identifiable in such a way that their design pressure and temperature can be readily determined.

A safety device (pressure relief valve) to control the risk of over-pressure in system components should be fitted. A termination from a safety pressure device should minimise the risk of damage to persons or materials. Suitable locations are a high temperature receptacle, in internal gully or else issue externally at ground level. High level termination from walls or on roofs could cause injury to people or animals below if the valve were to release scalding water and steam.

The pipe leading to the safety device and the collector should be of rigid and non-deformable construction, without any possibility of restriction or disclosure by any other fitted component.

A more detailed diagram of our recommended arrangement for a typical solar system is shown on page 20.

### Schematic Solar Indirect System

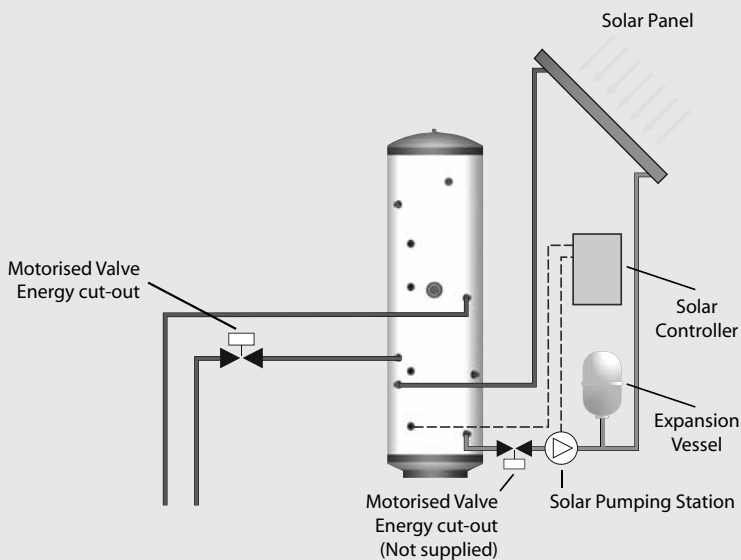

This provides all the necessary controls and safety devices necessary for the solar system i.e. the two port zone valve is wired as an energy cut out and the pump/valve will only allow heat transfer as required under control of the solar controller.

The solar pocket provided accommodates an 8mm diameter sensor which, with the sensor located in the solar collector (or in the flow pipe immediately adjacent to the collector), will provide the information required by the solar controller.

**Note: If the motorised valve is not used then any factory built hydraulic station for solar use MUST be fitted with suitable non-return valves in both flow and return pipes to prevent gravity circulation when the pump is not running.**

If there is a possibility of the solar controller that you install causing the cylinder temperature to exceed 80°C, under normal working conditions, then a Solar tempering valve must be fitted to the domestic hot water outlet of the cylinder. This must limit the hot water temperature to a maximum of 60°C. (ref building regulations part G3 3.63). Suitable plumbing configurations for installing this valve are shown on page 19 of this manual. NB. Any fitted Overheat thermostats may require resetting in the winter months to enable backup heat sources to heat the cylinder.

**Figure 1: Cold port of the blending valve connected to mains supply NOT ALLOWED**

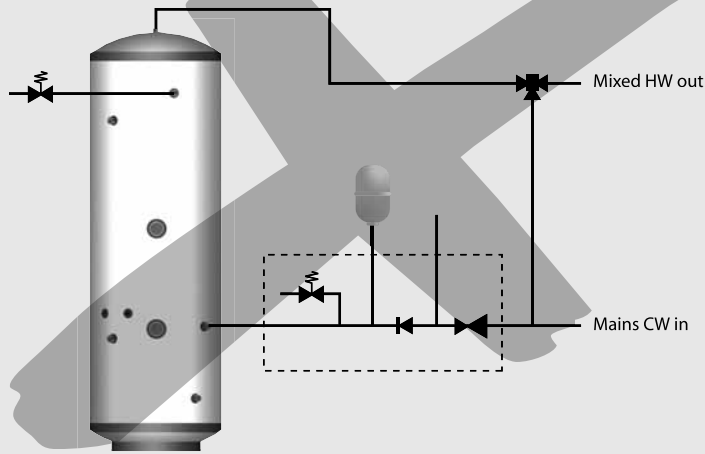

**Figure 2: Cold port of the blending valve connected to balanced cold supply - NON-RETURN VALVE MUST BE FITTED**

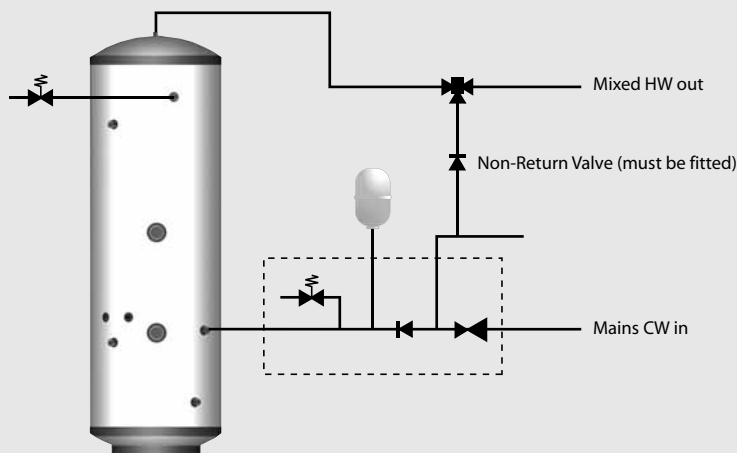

**Figure 3: Cold port of the blending valve connected to mains supply to the vessel after the inlet control group**

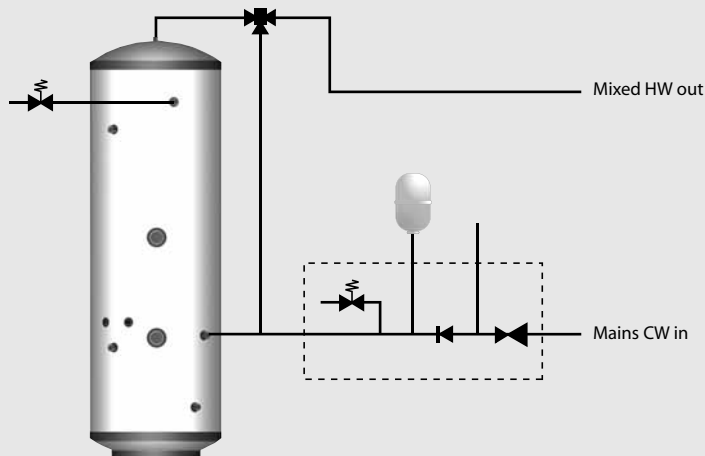

## Fitting Blending Valves To The Unvented Solflex Appliances

When fitting a blending valve to the unvented appliances, it is important that the installation does not contravene the G3, WRC and Health and Safety directives or the manufacturers recommendations. If this is the case, then the warranty should be null & void. The key requirements to comply with these regulations are: -

1. Any fitting or material in contact with potable water (e.g. a blending valve) must be approved by WRC or an equivalent body.
2. Connections or wiring arrangements must not bypass any safety devices.
3. Any expansion due to heating must not be allowed to expand back into the cold mains.
4. The settings of any safety devices must not be tampered with or adjusted.

The diagrams opposite shows how the blending valve can be piped onsite.

Figure 1 shows the cold water port of the blending valve connected to the mains cold water supply before the inlet control group. This arrangement is completely unacceptable and illegal because: -

- the water is allowed to expand in to mains cold water supply.
- the vessel will be charged to the incoming mains supply which may be considerably higher than the working pressure of the vessel.

If this arrangement is used then the warranty will not be valid.

Figure 2 shows the cold water port of the blending valve connected to the balanced cold water outlet. This arrangement will only be acceptable if an approved non-return valve is fitted, otherwise: -

- during the heating cycle, the water will expand back into the mains supply, as the regulating valve must not be relied upon to act as a check valve under all operating conditions.
- depending upon the characteristics of the blending valve, hot water may also flow from the balanced cold water taps.

Figure 3 shows the cold port of the blending valve connected to the cold water supply to the vessel after the inlet control group. This should be the preferred method. It is recommended that the installer should ensure that there is no gravity circulation in the pipework connected to the cold port. If necessary, this can be achieved by fitting a non-return valve or using a thermal trap.

# INSTALLATION

Schematic Showing Solar Wiring Requirements

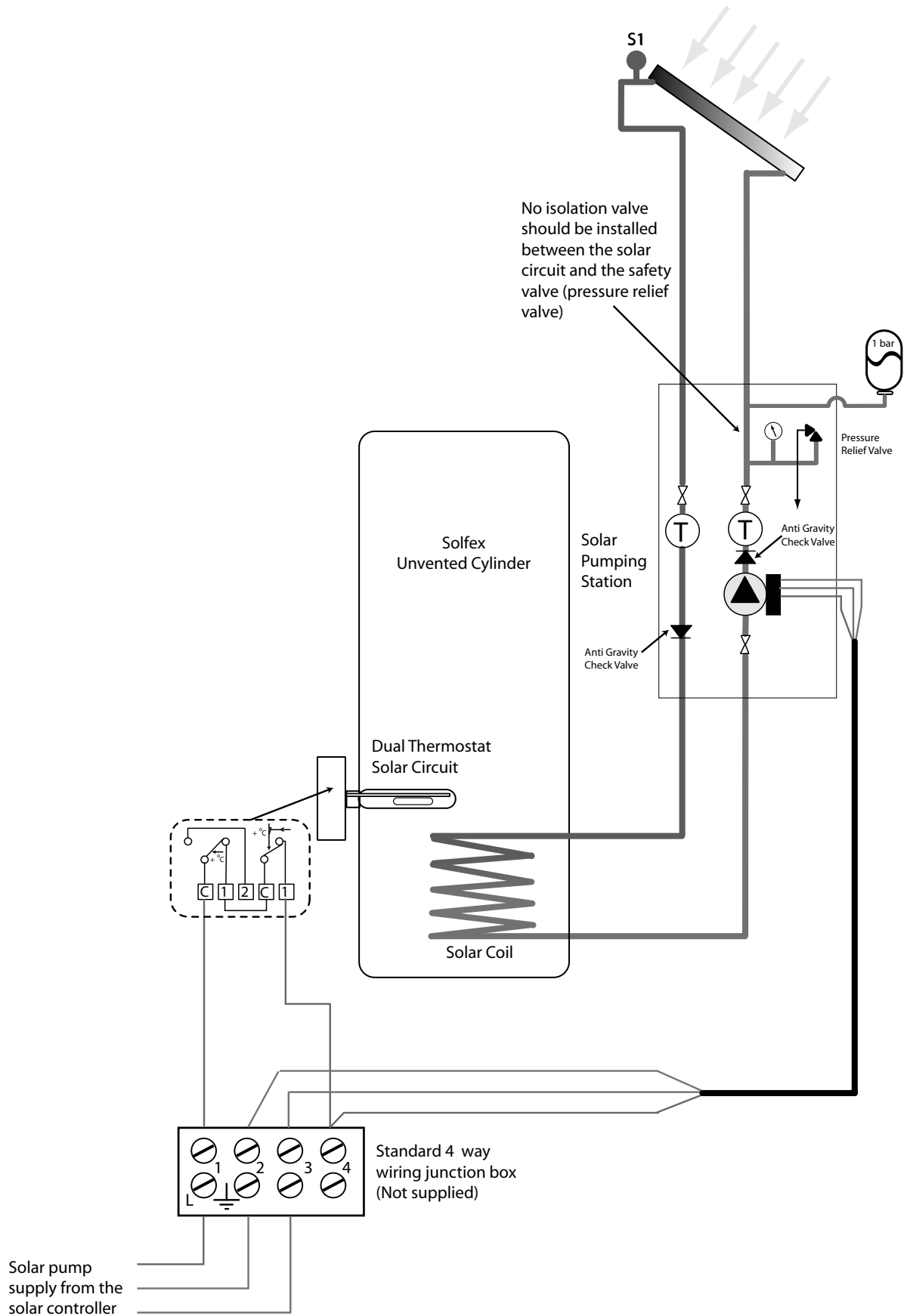

# INSTALLATION

## (S-PLAN) WIRING DIAGRAM WITH TWO 2 PORT VALVES AND BOILER CONTROLLED PUMP OVERRUN OPTION

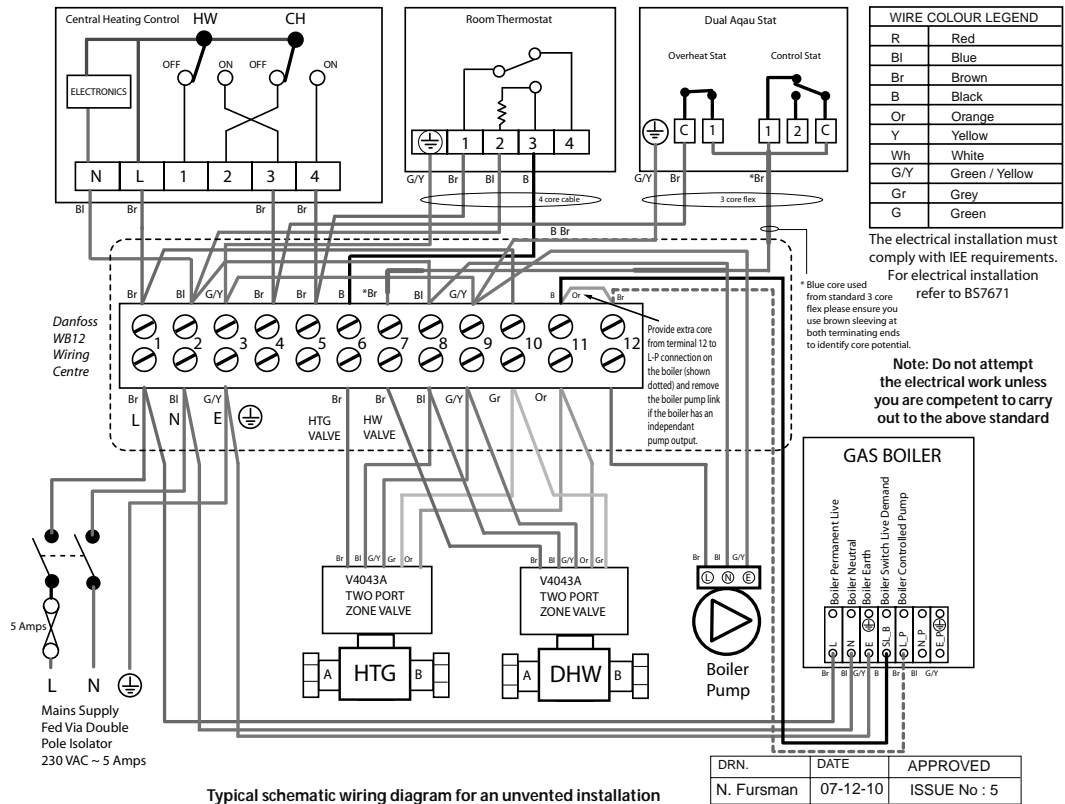

Typical schematic wiring diagram for an unvented installation

## (Y-PLAN) WIRING DIAGRAM WITH 3 PORT VALVE/2 PORT SAFETY VALVE AND BOILER CONTROLLED PUMP OVERRUN OPTION

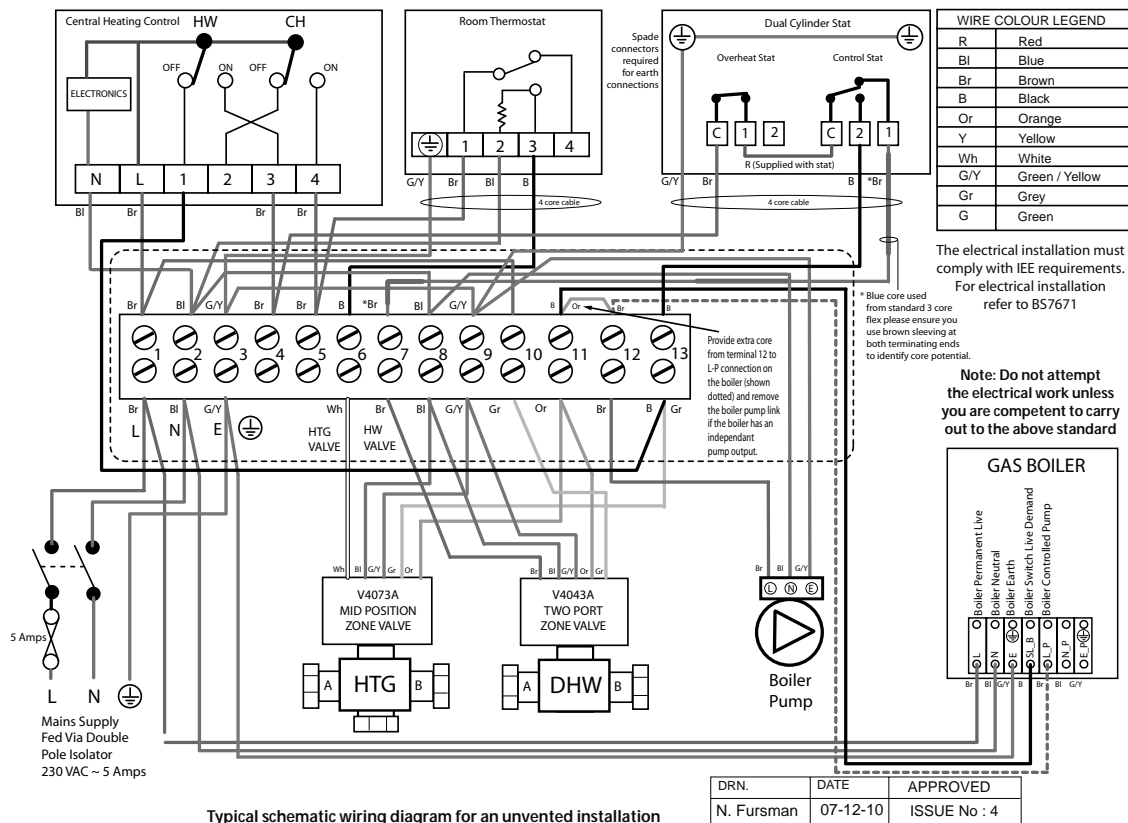

Typical schematic wiring diagram for an unvented installation

INSTALLATION

# INSTALLATION

Connections can come loose in transit, and all should be checked before installation.

Ensure that the immersion heater setting is 60°C and that the wiring is in accordance with the diagram.

Check the pressure on the air side of the expansion vessel = 3 bar. This must be done when the volume in the cylinder is cold.

Check that the drain cock is closed, and open all the cold and hot water taps and other terminal fittings. Allow the system to fill with water, and to run until there is no air left in the system. Close the taps and inspect the system closely for leaks.

Manually open the Relief Valves one by one and check that water is discharged and run freely through the tundish and out at the discharge point. The pipework should accept full bore discharge without overflowing at the tundish, and the valve should seat satisfactorily.

In line with good plumbing practice, use with excessive flux should be avoided.

When soldering above the cylinder, ensure flux/solder does not contaminate the cylinder below, since this can cause corrosion.

Allow the cylinder to heat to normal working temperature, then thoroughly flush the domestic hot and cold water pipework through each tap.

**NOTE:** If this appliance is to be installed in other than a single domestic dwelling ie. in an apartment block or student flats etc., the hot and cold water system will need to be disinfected in accordance with BS6700 and the Water Regulations.

Because the Solfex appliance is stainless steel, the use of chlorine as the disinfection agent can cause damage unless the appliance is adequately flushed and refilled with the mains water immediately on completion of the disinfection procedure. Damage caused through a failure to do this adequately will not be covered by the warranty.

For the above reasons we recommend the use of a non chlorine based disinfectant such as Fernox LP Sterox as manufactured by Cookson Electronics when carrying out disinfection of systems incorporating these appliances.

Allow the cylinder to heat to normal working temperature with whatever heat source is to be used, and check again for leaks. The pressure relief valve or the P&T valve should not operate during the heating cycle. If the P&T valve operates before the pressure relief valve due to high pressure, check that the inlet control group is fitted correctly.

The boiler/heating systems should be filled and commissioned in accordance with good practice following the guidance in BS 5449/the boiler manufacturers instructions. This includes adequately flushing the system to remove any debris that may have been introduced during installation/maintenance.

**NOTE:** This appliance is covered by BENCHMARK and the service record must be completed after commissioning and after every maintenance/service visit.

## IMPORTANT - DRAIN DOWN PROCEDURE

- 1 Switch off both the boiler and the immersion heater
- 2 Open the nearest hot tap and run all hot water until cold, then close it
- 3 Close the incoming cold main at the stop tap
- 4 **Hold open the pressure and temperature relief valve until water stops discharging into the tundish and leave it open**
- 5 Open all the taps in the property
- 6 Open the drain cock and ensure the pressure and temperature relief valve is held open until the cylinder is empty

Remove the filter from the combination inlet group clean and replace. Refill the system and open all hot taps until there is no air in the pipe work. **ENSURE CYLINDER IS DRAINED PRIOR TO CHECKING OR REMOVING FILTER FROM THE COMBINATION INLET GROUP.**

# USER INSTRUCTIONS

Your Solfex Unvented Cylinder is automatic in normal use, but requires routine maintenance which is normally carried out at least annually along with the boiler service. The maintenance must be carried out by a suitably competent tradesperson who is qualified to work on unvented cylinders. The checks/work needed are listed in the maintenance part of these Instructions.

The control thermostat for hot water temperature of the direct units is factory set at 60°C and it is not user adjustable. The indirect units are fitted with an adjustable store thermostat. However, this should be set between 60°C - 65°C to ensure hot water is sanitised to eliminate the risk of legionella.

When initially opening the taps, a small surge in flow may be experienced, which disappears as the pressure in the system stabilises. This is quite normal with these types of systems and does not indicate a fault.

In some areas the water will initially appear cloudy, but will quickly clear when left to stand. This is nothing to be concerned about and is due to aeration of the water.

**WARNING** - If water is seen flowing through the tundish, this indicates a fault condition which needs action.

If the discharge is hot and continuous, turn the boiler and/or the immersion heaters off, but do not turn off the cold water to the appliance until the discharge is cold.  
**Note:** The discharge may stop by itself as the discharge cools.

If the discharge is cold and intermittent, no immediate action is needed but this indicates a problem with the expansion vessel.

**However, in both cases you must call the Registered Installer / a suitably qualified, competent tradesperson, advise them that you have an unvented cylinder and request a maintenance visit.**

**DO NOT**, at any time, tamper in any way with the safety valves or overheat thermostats/wiring.

# SERVICING

The Registered Installer is responsible for the safe installation and operation of the system. The installer must also make his customer aware that periodic maintenance of the equipment is essential for safety.

Maintenance periods will vary for many reasons. Solfex Limited recommend a maximum of 12 months to coincide with boiler maintenance. Experience of local water conditions may indicate that more frequent maintenance is desirable, eg, when water is particularly hard, scale-forming or where the water supply contains a high proportion of solids, eg, sand. Maintenance must include the following:

1. Check and clean filter
2. Manually check the operation of the temperature relief valve.
3. Manually check the operation of the expansion relief valve.
4. Check discharge pipes from temperature and expansion relief valves are free from obstruction and blockage and are not passing any water.
5. Check the condition and if necessary descale the heat exchangers in hard water areas.
6. Check that water pressure downstream of pressure reducing valve is within the manufacturers limits.
7. Check operation of motorised valve.
8. Check the pressure on the air side of the expansion vessel. This must be done when the volume in the cylinders is cold.
9. Check and advise the householder not to place any clothing or other combustible materials against or on top of this appliance.
10. On completion of the work, fill in the Service Record part of the Benchmark section of the manual.

## IMPORTANT NOTE

**When draining down the appliance for any reason, the instructions provided in the Commissioning Section MUST be followed to prevent potential damage to the cylinder.**



## Scale

In hard water areas it is recommended that an in-line scale inhibitor is fitted. Reducing the temperature of the stored water will reduce the rate at which scale forms. If the recovery rate is badly affected, this is an indication that scaling may have occurred. In this event, follow the procedures as recommended by a reputable Water Treatment Company.

## General

No water at the tap. Check that the mains water supply is turned ON. Check the line strainer is not blocked. Check that the combination valve has been fitted so that water is flowing in the correct direction.

If the water at the tap is cold, ensure that the boiler has been switched ON and is working correctly. Check that there are no air locks in the primary system. ISOLATE THE UNIT AT THE MAINS ELECTRIC SUPPLY AND THEN CHECK THE FOLLOWING:

- i. The cylinder thermostat
- ii. The thermal cut-out, which can be re-set by pushing the red button
- iii. The motorised valve
- iv. The boiler thermostat
- v. The boiler thermostat cut-out (if fitted)

ANY ENERGY CUT-OUT MUST NEVER BE BY-PASSED UNDER ANY CIRCUMSTANCES.

If the units are not getting hot and the heat source is electrical, ensure that the immersion heaters are isolated from the mains before re-setting the energy cut-out. If the immersion heater(s) need replacing this should be done with the units supplied from Solfex Limited.

## Discharge From Relief Valves

If cold water is discharging from the expansion relief valve into the tundish check the pressure on the expansion vessel when cold and recharge if necessary.

If the fault continues and the problem cannot be stopped by operating the easing control a few times then either the Pressure Reducing Valve or the Relief Valve may be at fault. If the cold water pressure is too high, this would suggest that the Pressure Reducing Valve is at fault and the Solfex approved replacement should be fitted. If the pressure is correct then the Relief Valve will require replacing with a Solfex approved component.

**See Commissioning for drain down procedure.**

If there is an overheat fault and very hot water is being discharged, turn off the heat source, **but not the water supply.**

When the supply is cool, check thermostats and energy cut-outs in the boiler and immersion heaters and replace the faulty component with a unit supplied by Solfex and check that it works correctly before returning the system to full operation.

# SERVICING

Fault - No Hot Water (Direct)

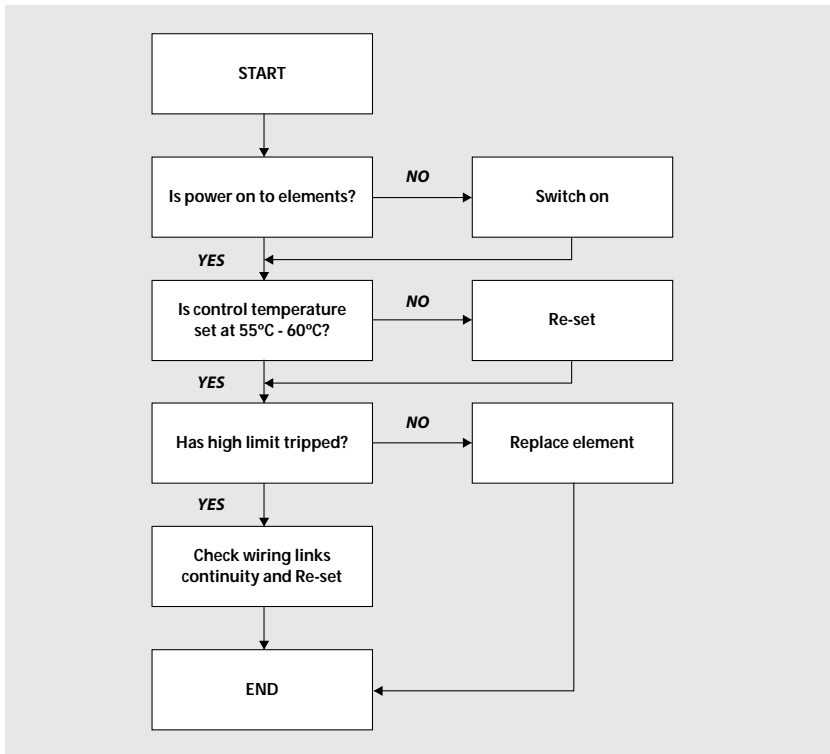

Fault - No Hot Water (Indirect)

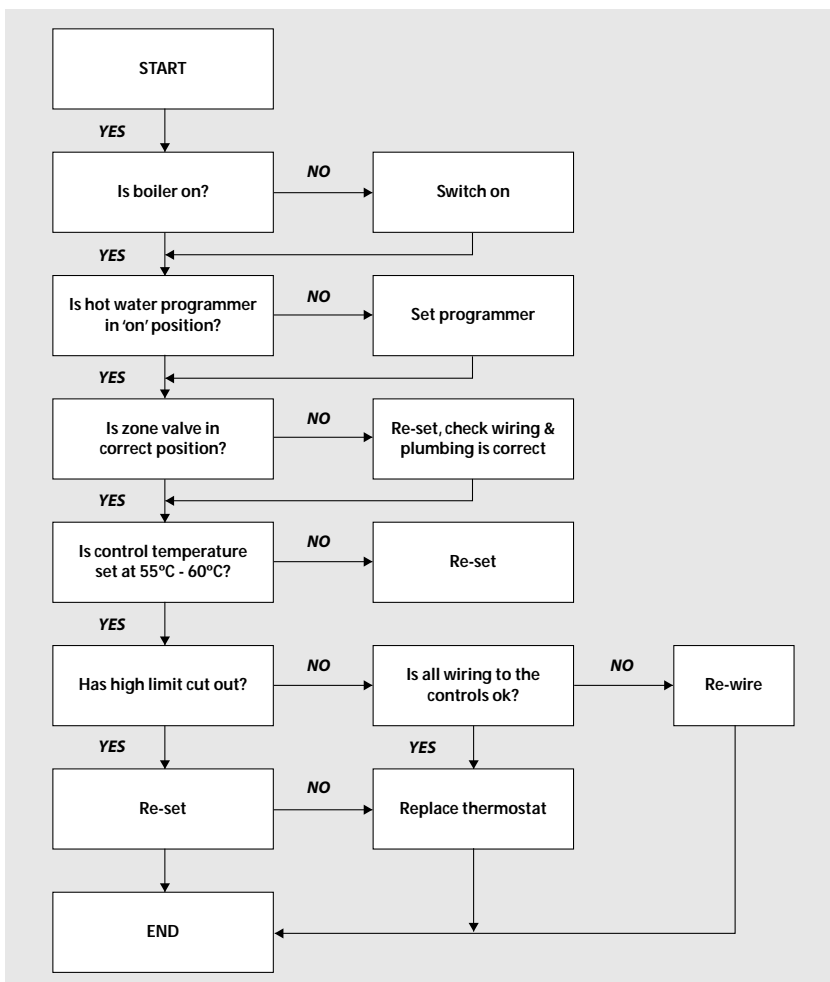

FAULT FINDING

Fault - Poor Water Flow At Hot Taps

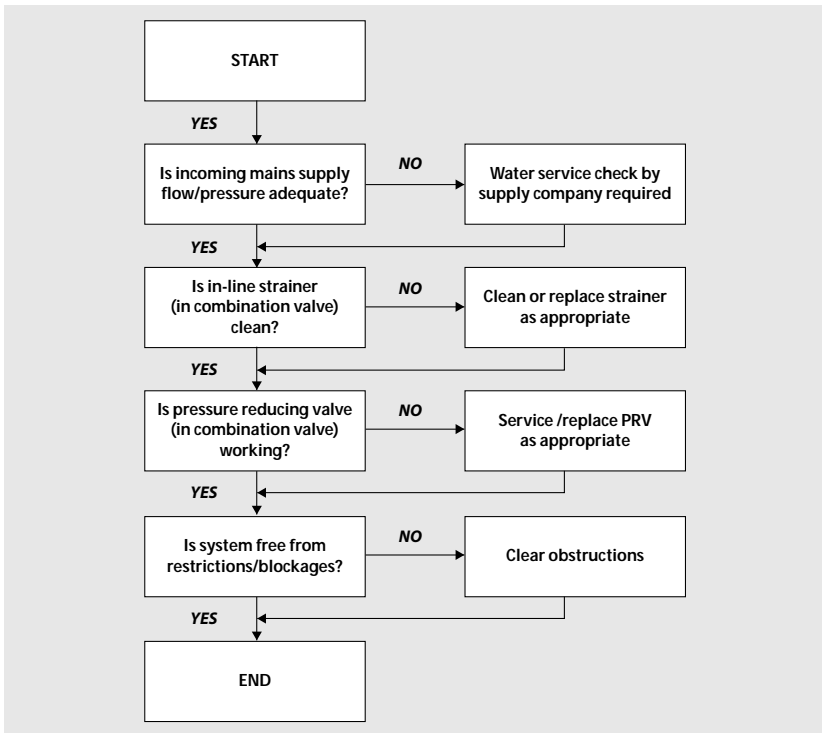

Fault - Water Discharge Into Tundish

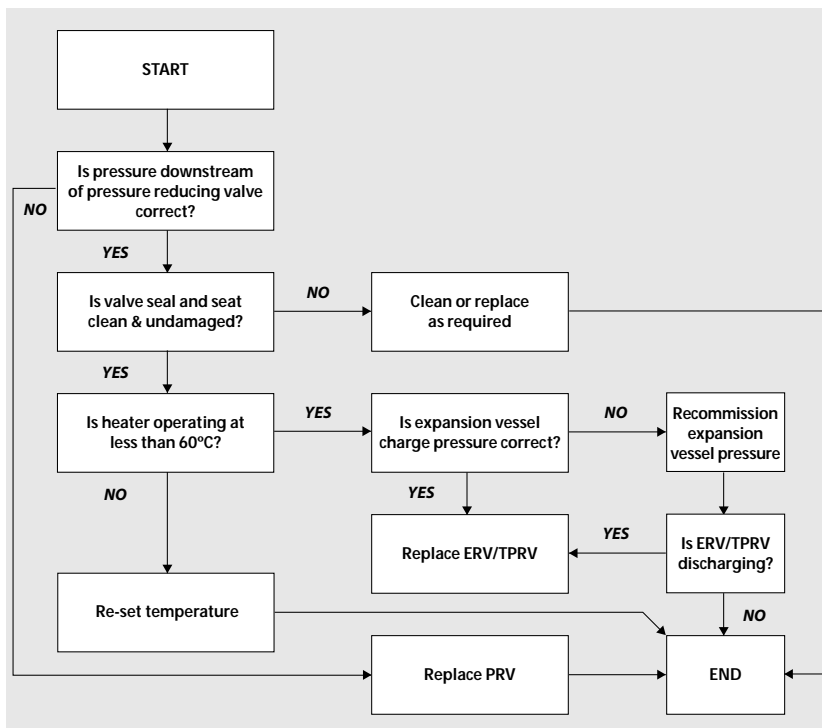

# SERVICING

SPARE PARTS LIST			
	Description	Quantity	Stock Code No.
1	3kW immersion element	1	SH001
2	22mm 90° compression elbow c/w/drain	1	SF003
3	Pressure and temperature relief valve 6 bar 95°C	1	SG001
4	Inlet group set at 3 bar c/w expansion relief valve set at 4.75 bar	1	SG012
5	¾" flexible hose	1	SG003
7	12 litre expansion vessel	1	XG190
8	18 litre expansion vessel	1	XG191
9	24 litre expansion vessel	1	XG192
10	35 litre expansion vessel	1	XG193
11	Wall mounting bracket for 35 litre expansion vessel	1	XG058
12	22mm 2 port valve (indirects only)	1	XG083
13	Junction wiring box (12 way)	1	XG129
14	Control and overheat limit thermostat	1	XG168
15	15mm x 22mm tundish	1	XG173

## Water Savings

### Water Related Costs Can Be Reduced By Good Plumbing Practice

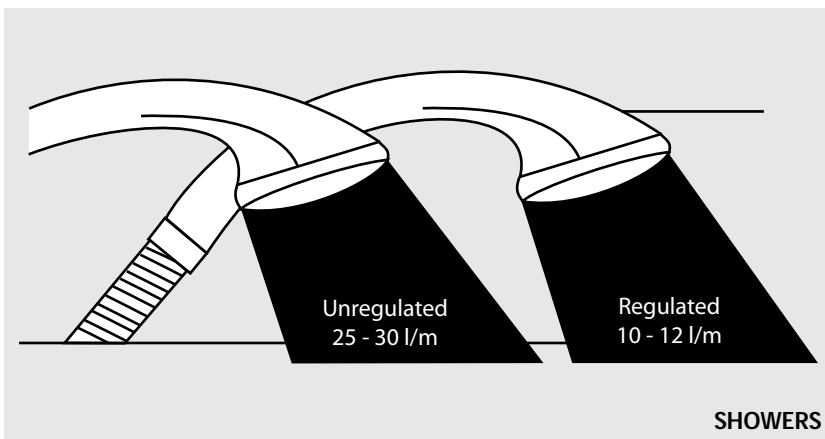
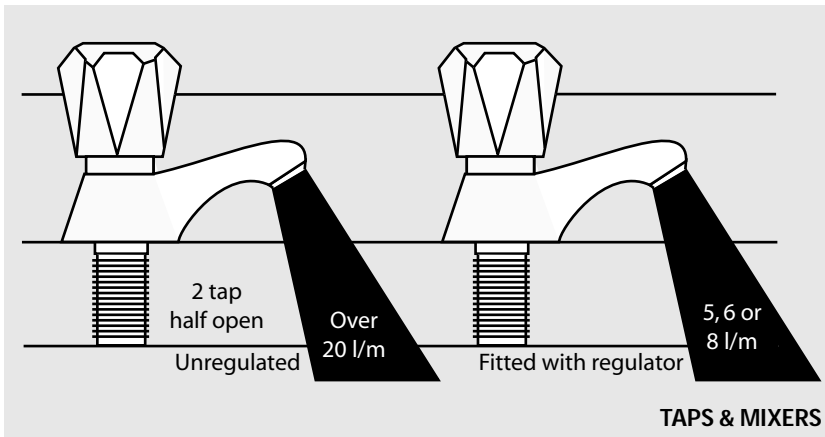

Vast quantities of water are needlessly run off to waste due to Taps, Mixers and Showers discharging flow rates far in excess of the rates required for them to perform their duties.

The contrasting flow rates shown on this leaflet clearly illustrate the savings that can be made whilst still providing a good performance.

British made AquafLOW Regulators provide constant flow rates by automatically compensating for supply pressure changes between 1 bar & 10 bars.

To facilitate installation into the wide range of plumbing equipment which is encountered in the U.K, Four Fixing Options are available:-

#### Options For Showers

1. MXF "DW" Range - For fitting behind Fixed Shower Heads or onto Flexible Hoses for Handshowers (preferably onto the inlet end when lightweight hoses are used).
2. Compression Fitting Range. "In Line" regulators as in Option 4 for Taps & Mixers.

Information by courtesy of  
**AQUAFLOW REGULATORS LTD**

Haywood House, 40 New Road, Stourbridge, West Midlands DY8 1PA  
TELEPHONE (01384) 442611 FAX: (01384) 442612

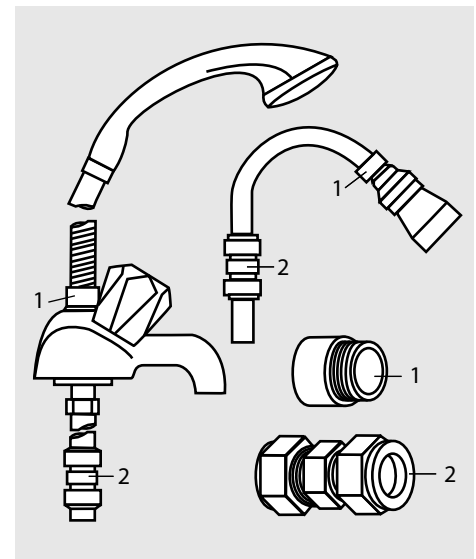

#### 4 Fixing Options For Taps & Mixers

1. MK Range - Combined Regulators & Aerators for screwing onto Taps & Mixers with internal or external threads on their noses. Anti Vandal models also available.
2. MR05-T Range - Internal Regulators. Push-fit into Tap or Mixer seats. Produced in three sizes - 12.5mm (BS1010), 12mm & 10mm, Flangeless models also available for Taps with Low Lift washers.
3. MXF Standard Range - Screw on tail models for Taps & Mixers. Fix onto the tails before fitting the tap connectors. Available in 3/8", 1/2", 3/4" and 1" BSP.
4. Compression Fitting Range - "In Line" regulators housed in 15mm & 22mm CXC Couplers & Isolating Valves. "UKWFBS" listed by the Water Research Centre. Isolation valves available for slotted screwdriver operation or with coloured plastic handles. Now available also in plastic bodied push-fit couplers & valves.

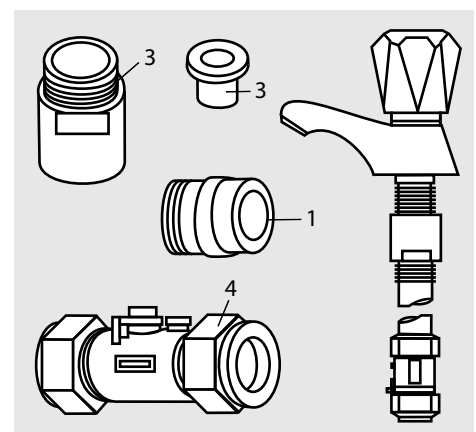

## MANUAL HANDLING OF APPLIANCE PRODUCTS

### Description

Manual handling means any transporting or supporting of a load (including lifting, putting down, pushing, pulling, carrying or moving) by hand or bodily force.

### Scope

This assessment will cover the largest product supplied by Solfex Limited.

For specific weights and dimensions please refer to technical data section.

### Main Hazards

Vision may not be clear due to the size of the products. Adopting an incorrect method of lifting may cause injury, attempting to lift these products will require help from others. (Team lifts)

### Control Measures

#### Manual lifting procedure

The lift, key factors in safe lifting are:

- a. **Balance**
- b. **Position of back**
- c. **Positioning of the arms and body**
- d. **The hold**
- e. **Taking the lead for team lifts**

- a. **Balance** - Since balance depends essentially upon the position of the feet, they should be apart about hip breadth with one foot advanced giving full balance sideways and forward without tension. In taking up this position, lifting is done by bending at the knees instead of the hips and the muscles that are brought into use are those of the thigh and not the back.
- b. **Position of back** - Straight - not necessary vertical. The spine must be kept rigid, this coupled with a bent knee position, allows the centre line of gravity of the body to be over the weight so reducing strain.
- c. **Positioning of arms and body** - The further arms are away from the side, the greater the strain on the shoulders, chest and back. Keep elbows close to the body arms should be straight.
- d. **The hold** - Before lifting ensure you have a good hold.

- e. **Taking the lead for team lifts**- As more than one person is required for these products ensure that one person is taking the lead. **This may be you** so ensure that each person that is helping is made aware of the weight and of the items listed within this assessment. Make sure you and any others helping know the route you intend to take that it is clear of any obstructions. Never jerk the load as this will add a little extra force and can cause severe strain to the arms, back and shoulders. If there are steps involved decide on where you will stop and take a rest period. Move smoothly and in unison taking care to look and listen to others helping with the lift. Where possible use a sack truck to move the product over long flat distances, only lift the products when necessary. If in doubt stop and get more help.

#### Individual capability

Individual capability plays an important part in handling these products. Persons above average build and strength will find it easier and should be in good health. Persons below average build and strength may require more rest periods during the handling process.

Pregnant women should not carry out this operation.

Persons who are not in good health should seek medical advice prior to commencing any lifting or manual handling operation.

#### Residual risk

Following the guidelines given above will reduce any risk to injury.

All persons carrying out this operation must be fully trained and copies of the specific risk assessment made available for inspection and use in their training process.

Further guidance on Manual Handling can be obtained from the Health and Safety Executive. Manual Handling Operations Regulations 1992.



## MAINS PRESSURE HOT WATER STORAGE SYSTEM COMMISSIONING CHECKLIST

This Commissioning Checklist is to be completed in full by the competent person who commissioned the storage system as a means of demonstrating compliance with the appropriate Building Regulations and then handed to the customer to keep for future reference.

Failure to install and commission this equipment to the manufacturer's instructions may invalidate the warranty but does not affect statutory rights.

Customer Name \_\_\_\_\_ Telephone Number \_\_\_\_\_  
 Address \_\_\_\_\_  
 Cylinder Make and Model \_\_\_\_\_  
 Cylinder Serial Number \_\_\_\_\_  
 Commissioned by (print name) \_\_\_\_\_ Registered Operative ID Number \_\_\_\_\_  
 Company Name \_\_\_\_\_ Telephone Number \_\_\_\_\_  
 Company Address \_\_\_\_\_ Commissioning Date \_\_\_\_\_

**To be completed by the customer on receipt of a Building Regulations Compliance Certificate\*:**

Building Regulations Notification Number (if applicable) \_\_\_\_\_

**ALL SYSTEMS PRIMARY SETTINGS (indirect heating only)**

Is the primary circuit a sealed or open vented system? Sealed  Open   
 What is the maximum primary flow temperature? \_\_\_\_\_ °C

**ALL SYSTEMS**

What is the incoming static cold water pressure at the inlet to the system? \_\_\_\_\_ bar  
 Has a strainer been cleaned of installation debris (if fitted)? Yes  No   
 Is the installation in a hard water area (above 200ppm)? Yes  No   
 If yes, has a water scale reducer been fitted? Yes  No   
 What type of scale reducer has been fitted? \_\_\_\_\_  
 What is the hot water thermostat set temperature? \_\_\_\_\_ °C  
 What is the maximum hot water flow rate at set thermostat temperature (measured at high flow outlet)? \_\_\_\_\_ l/min  
 Time and temperature controls have been fitted in compliance with Part L of the Building Regulations? Yes   
 Type of control system (if applicable) Y Plan  S Plan  Other   
 Is the cylinder solar (or other renewable) compatible? Yes  No   
 What is the hot water temperature at the nearest outlet? \_\_\_\_\_ °C  
 All appropriate pipes have been insulated up to 1 metre or the point where they become concealed Yes

**UNVENTED SYSTEMS ONLY**

Where is the pressure reducing valve situated (if fitted)? \_\_\_\_\_  
 What is the pressure reducing valve setting? \_\_\_\_\_ bar  
 Has a combined temperature and pressure relief valve and expansion valve been fitted and discharge tested? Yes  No   
 The tundish and discharge pipework have been connected and terminated to Part G of the Building Regulations Yes   
 Are all energy sources fitted with a cut out device? Yes  No   
 Has the expansion vessel or internal air space been checked? Yes  No

**THERMAL STORES ONLY**

What store temperature is achievable? \_\_\_\_\_ °C  
 What is the maximum hot water temperature? \_\_\_\_\_ °C

**ALL INSTALLATIONS**

The hot water system complies with the appropriate Building Regulations Yes   
 The system has been installed and commissioned in accordance with the manufacturer's instructions Yes   
 The system controls have been demonstrated to and understood by the customer Yes   
 The manufacturer's literature, including Benchmark Checklist and Service Record, has been explained and left with the customer Yes

Commissioning Engineer's Signature \_\_\_\_\_  
 Customer's Signature \_\_\_\_\_  
 (To confirm satisfactory demonstration and receipt of manufacturer's literature)

\*All installations in England and Wales must be notified to Local Authority Building Control (LABC) either directly or through a Competent Persons Scheme. A Building Regulations Compliance Certificate will then be issued to the customer.





## SERVICE RECORD

It is recommended that your hot water system is serviced regularly and that the appropriate Service Record is completed.

### Service Provider

Before completing the appropriate Service Record below, please ensure you have carried out the service as described in the manufacturer's instructions.

**SERVICE 1**    Date \_\_\_\_\_

Engineer Name \_\_\_\_\_

Company Name \_\_\_\_\_

Telephone Number \_\_\_\_\_

Comments \_\_\_\_\_

\_\_\_\_\_

\_\_\_\_\_

Signature \_\_\_\_\_

**SERVICE 2**    Date \_\_\_\_\_

Engineer Name \_\_\_\_\_

Company Name \_\_\_\_\_

Telephone Number \_\_\_\_\_

Comments \_\_\_\_\_

\_\_\_\_\_

\_\_\_\_\_

Signature \_\_\_\_\_

**SERVICE 3**    Date \_\_\_\_\_

Engineer Name \_\_\_\_\_

Company Name \_\_\_\_\_

Telephone Number \_\_\_\_\_

Comments \_\_\_\_\_

\_\_\_\_\_

\_\_\_\_\_

Signature \_\_\_\_\_

**SERVICE 4**    Date \_\_\_\_\_

Engineer Name \_\_\_\_\_

Company Name \_\_\_\_\_

Telephone Number \_\_\_\_\_

Comments \_\_\_\_\_

\_\_\_\_\_

\_\_\_\_\_

Signature \_\_\_\_\_

**SERVICE 5**    Date \_\_\_\_\_

Engineer Name \_\_\_\_\_

Company Name \_\_\_\_\_

Telephone Number \_\_\_\_\_

Comments \_\_\_\_\_

\_\_\_\_\_

\_\_\_\_\_

Signature \_\_\_\_\_

**SERVICE 6**    Date \_\_\_\_\_

Engineer Name \_\_\_\_\_

Company Name \_\_\_\_\_

Telephone Number \_\_\_\_\_

Comments \_\_\_\_\_

\_\_\_\_\_

\_\_\_\_\_

Signature \_\_\_\_\_

**SERVICE 7**    Date \_\_\_\_\_

Engineer Name \_\_\_\_\_

Company Name \_\_\_\_\_

Telephone Number \_\_\_\_\_

Comments \_\_\_\_\_

\_\_\_\_\_

\_\_\_\_\_

Signature \_\_\_\_\_

**SERVICE 8**    Date \_\_\_\_\_

Engineer Name \_\_\_\_\_

Company Name \_\_\_\_\_

Telephone Number \_\_\_\_\_

Comments \_\_\_\_\_

\_\_\_\_\_

\_\_\_\_\_

Signature \_\_\_\_\_

**SERVICE 9**    Date \_\_\_\_\_

Engineer Name \_\_\_\_\_

Company Name \_\_\_\_\_

Telephone Number \_\_\_\_\_

Comments \_\_\_\_\_

\_\_\_\_\_

\_\_\_\_\_

Signature \_\_\_\_\_

**SERVICE 10**    Date \_\_\_\_\_

Engineer Name \_\_\_\_\_

Company Name \_\_\_\_\_

Telephone Number \_\_\_\_\_

Comments \_\_\_\_\_

\_\_\_\_\_

\_\_\_\_\_

Signature \_\_\_\_\_





**kiwa**  
approved  
product



UK BUILDING REGULATIONS

**kiwa**  
approved  
product



UK WATER SUPPLY REGULATIONS

**benchmark**

COLLECTIVE MARK

THE MARK OF QUALITY FOR THE INSTALLATION, COMMISSIONING AND SERVICING OF DOMESTIC HEATING AND HOT WATER SYSTEMS



Energy Arena, Bannister Hall Works  
Higher Walton, Preston PR5 4DZ  
Tel: 01772 312847 Fax: 01772 335277  
[www.solfex.co.uk](http://www.solfex.co.uk)